



MECCANO



SUPPLEMENTARY INSTRUCTIONS No. 13.

The number of models which may be made with Meccano is added to year by year, new and excellent designs being continually introduced. Users should make a point of securing a new Book of Instructions each year.

NEW MECCANO PARTS

which have been recently added to the hobby. Their many uses are described and illustrated on pages 2 and 3.



No. 10. Flat Bracket (½ doz.) s. d.
0 4

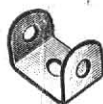

„ 11. Double Bracket (see page 3) ... each 0 2

„ 65. Centre Fork... .. . 0 2



No. 62. Crank (see page 2) each s. d.
0 7



„ 63. Coupling (see page 2) „ 0 7

„ 64. Ship's Funnel per pair 0 2

MECCANO Ltd., LIVERPOOL, ENG.

Price 6d.

COPYRIGHT, 1913
BY MECCANO LTD

New Meccano Coupling

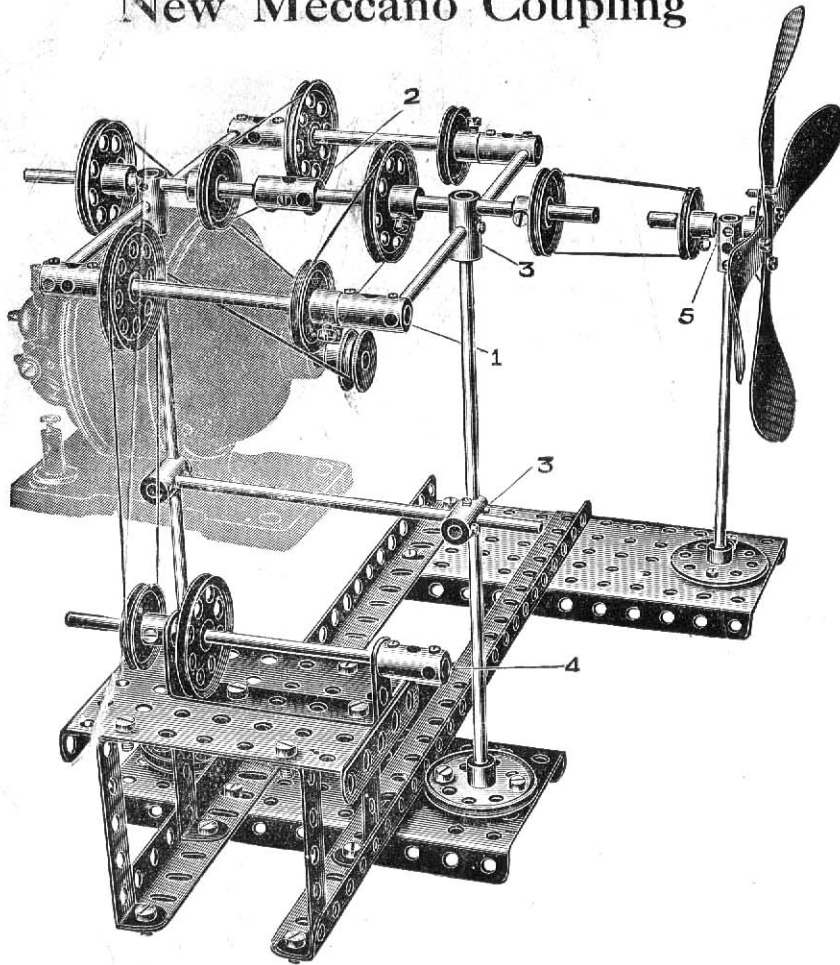

This illustration shows some of the uses to which the newly-invented MECCANO COUPLING may be applied:-

- | | |
|------------------------------|-------------------------|
| 1. Bearing for Countershaft. | No. 4. Chuck. |
| 2. Coupling for Shafting. | 5. Bearing for Spindle. |
| 3. Bearing for Shafting. | |

New Meccano Crank

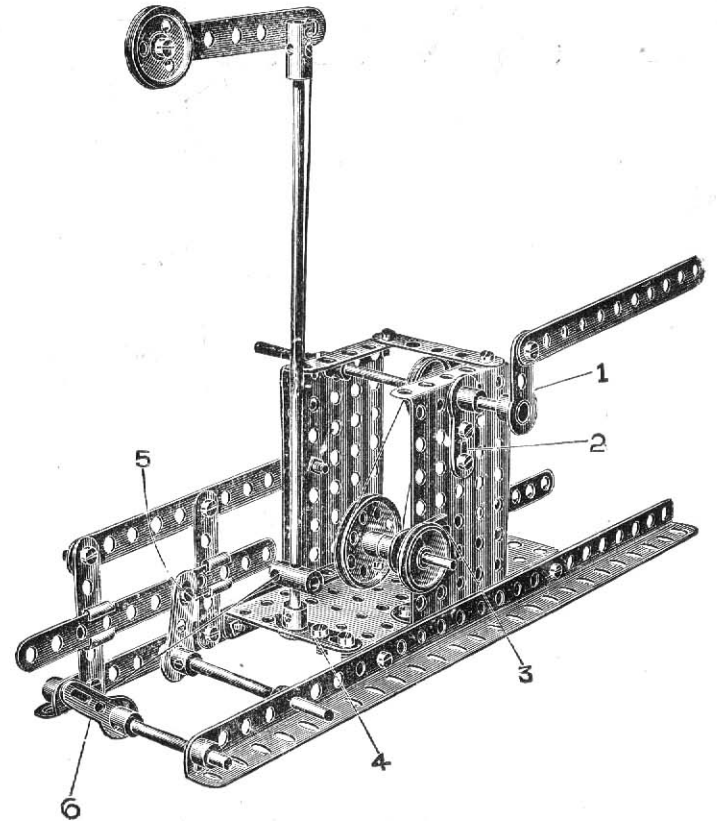

This illustration shows some of the uses to which the newly-invented MECCANO CRANK may be applied:-

- | | |
|--------------------------|--------------------------|
| No. 1. Crank. | No. 4. Footstep Bearing. |
| " 2. Reinforced Bearing. | 5. Rocking Lever. |
| " 3. Extended Bearing. | 6. Operating Lever. |

New Meccano Double Bracket.

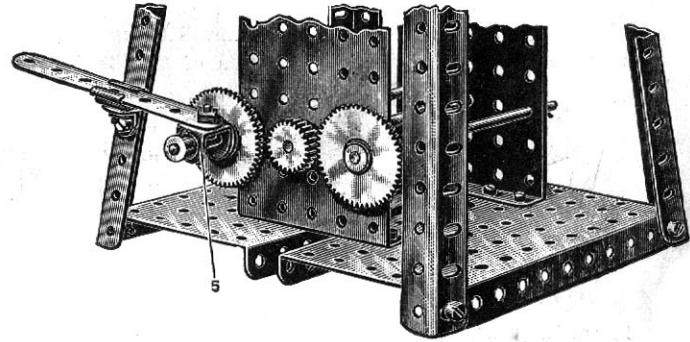
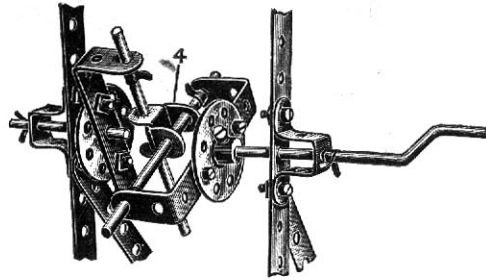
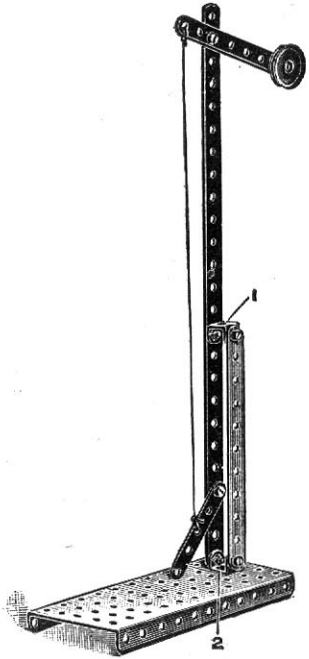

This illustration shows some of the uses to which the newly-invented MECCANO DOUBLE BRACKET may be applied :

- No. 1. Distancing Bracket.
- „ 2. „ Foot Bracket.
- „ 3. Guide Bracket.
- „ 4. Reversed Double Bearing for Cross Shafts.
- „ 5. Pivotal Sliding Bracket.
- „ 6. Distending Bracket for Side Frames of Crane.
- „ 7. Slung Bracket for Pulleys of Crane Tie.

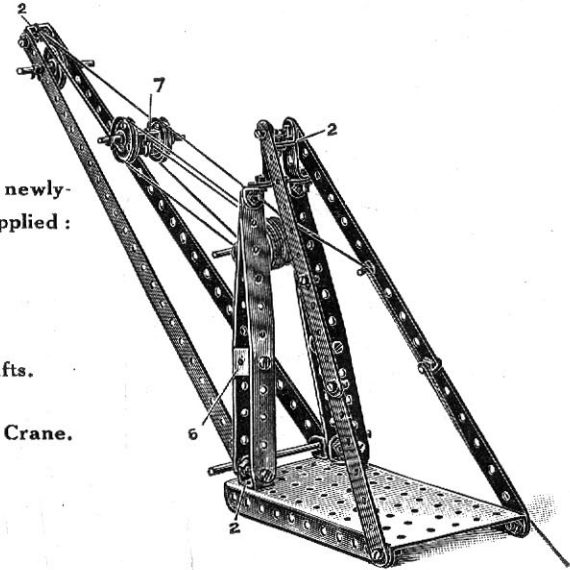
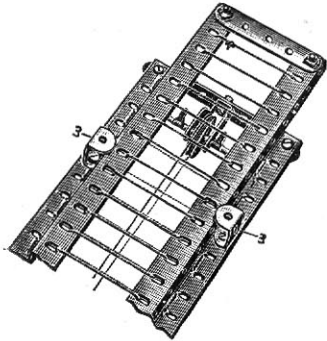

Types of Trucks and Luggage Carts

(MADE WITH MECCANO OUTFIT NO. 1.)

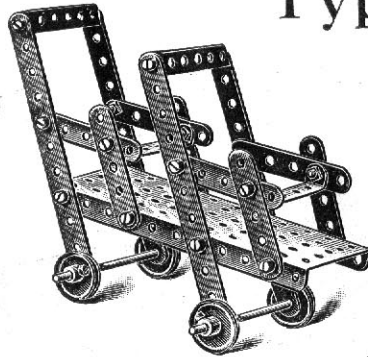

PARTS REQUIRED.

4 of No. 2
8 " " 5
4 " " 60
2 " " 15
4 " " 22
20 " " 37
1 " " 52

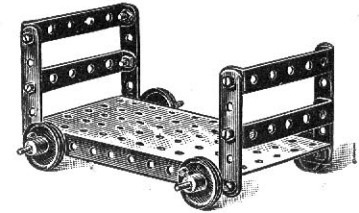
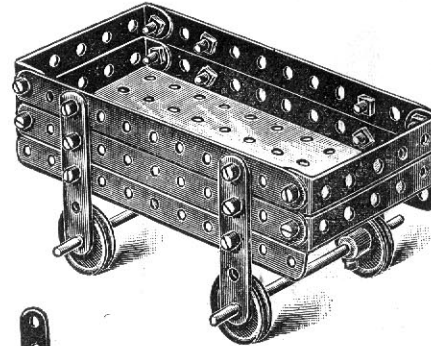

PARTS REQUIRED.

4 of No. 5	4 of No. 22
4 " " 60	12 " " 37
2 " " 15	1 " " 52

PARTS REQUIRED.

6 of No. 5
4 " " 10
2 " " 15
4 " " 22
10 " " 37
1 " " 52

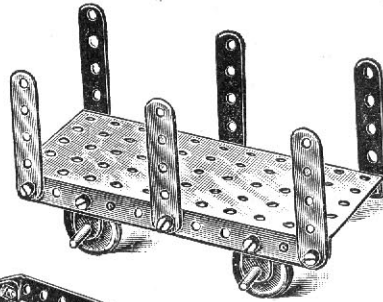

PARTS REQUIRED.

4 of No. 2	4 of No. 22
4 " " 5	20 " " 37
4 " " 60	1 " " 52
2 " " 15	

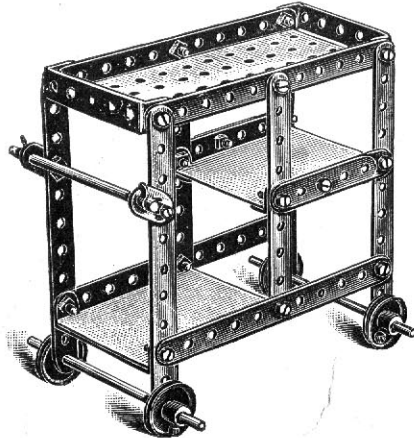
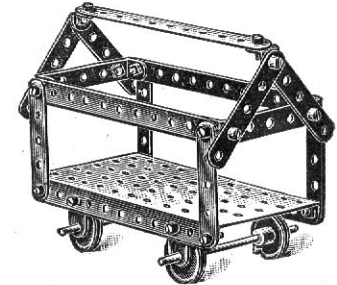

PARTS REQUIRED.

6 of No. 2
8 " " 5
4 " " 60
2 " " 10
4 " " 12
3 " " 15
4 " " 22
2 " " 35
20 " " 37
1 " " 52

The two lower platforms are constructed out of pieces of cardboard, their outer edges resting on $2\frac{1}{2}$ " bent strips and their inner edges on angle brackets.

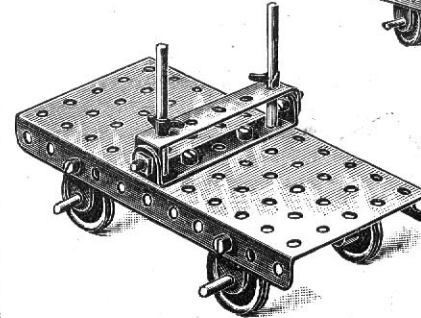

2 of No. 60	4 of No. 22
4 " " 10	2 " " 35
2 " " 15	8 " " 37
2 " " 17	1 " " 52

PARTS REQUIRED.

3 of No. 2
8 " " 5
2 " " 60
4 " " 10
2 " " 12
2 " " 15
4 " " 22
20 " " 37
1 " " 52

Types of Cranes

(MADE WITH MECCANO OUTFIT NO. 1.)

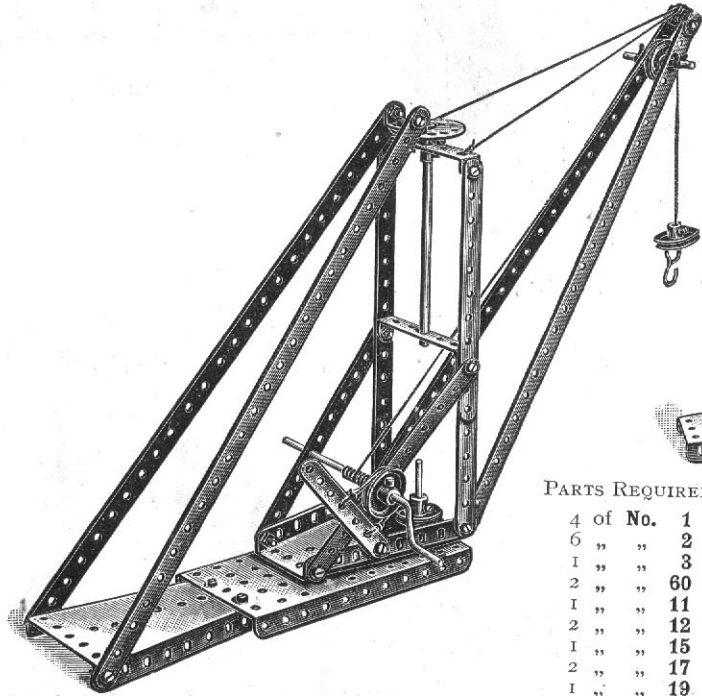

PARTS REQUIRED.

4	of	No.	1
6	"	"	2
1	"	"	3
2	"	"	60
1	"	"	11
2	"	"	12
1	"	"	15
2	"	"	17
1	"	"	19
4	"	"	22
2	"	"	22A
1	"	"	24
4	"	"	35
20	"	"	37
1	"	"	57
1	"	"	52
2	"	"	54

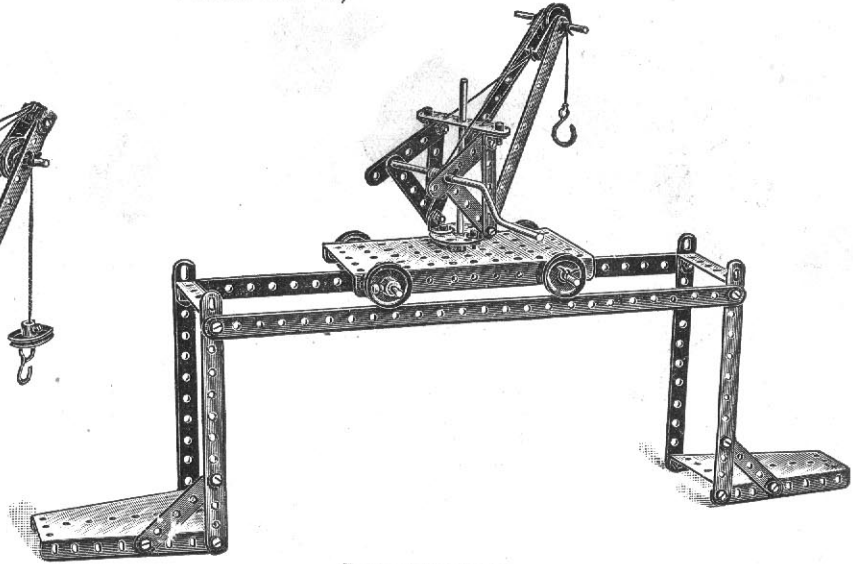

PARTS REQUIRED.

2	of	No.	1
6	"	"	2
9	"	"	5
2	"	"	60
4	"	"	10
4	"	"	12
3	"	"	15
1	"	"	17
1	"	"	19
4	"	"	22
2	"	"	22A
1	"	"	24
6	"	"	35
20	"	"	37
1	"	"	57
1	"	"	44
1	"	"	52
2	"	"	54

Scales

(MADE WITH MECCANO OUTFIT NO. 1.)

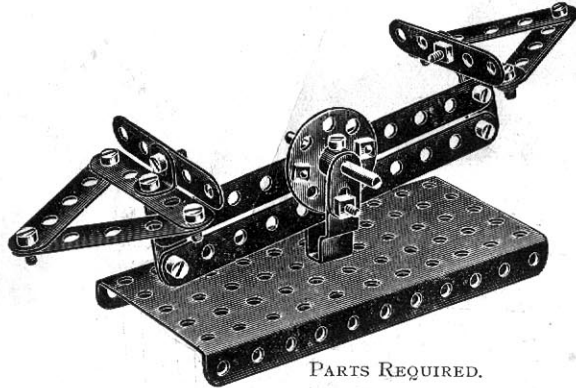

PARTS REQUIRED.

2	of	No.	2
8	"	"	5
4	"	"	10
4	"	"	12
1	"	"	17
1	"	"	24
19	"	"	37
1	"	"	44
1	"	"	52

Well Windlass

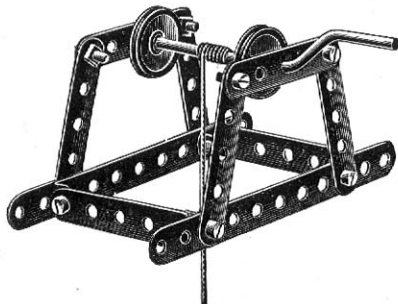

PARTS REQUIRED.

2	of	No.	2
8	"	"	5
4	"	"	12
1	"	"	19
2	"	"	22
12	"	"	37

Types of Cranes

(MADE WITH MECCANO OUTFIT NO. 1.)

Swivelling Crane

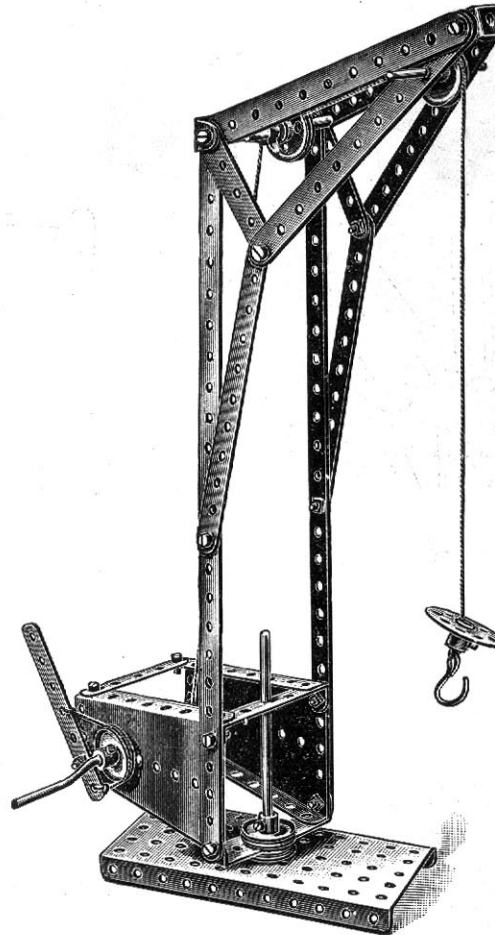

PARTS REQUIRED.

2	of	No.	1
6	"	"	2
1	"	"	3
4	"	"	5
3	"	"	60
1	"	"	11
1	"	"	15
2	"	"	17
1	"	"	19
4	"	"	22
2	"	"	22A
1	"	"	24
4	"	"	35
18	"	"	37
1	"	"	57
1	"	"	44
1	"	"	52
2	"	"	54

The hoisting cord after passing over the pulley at the end of the jib, passes over a pulley running in a cranked bent strip secured by a nut and bolt to the 2½" bent strip at the back of the jib.

Joy Wheel

(MADE WITH MECCANO OUTFIT NO. I.)

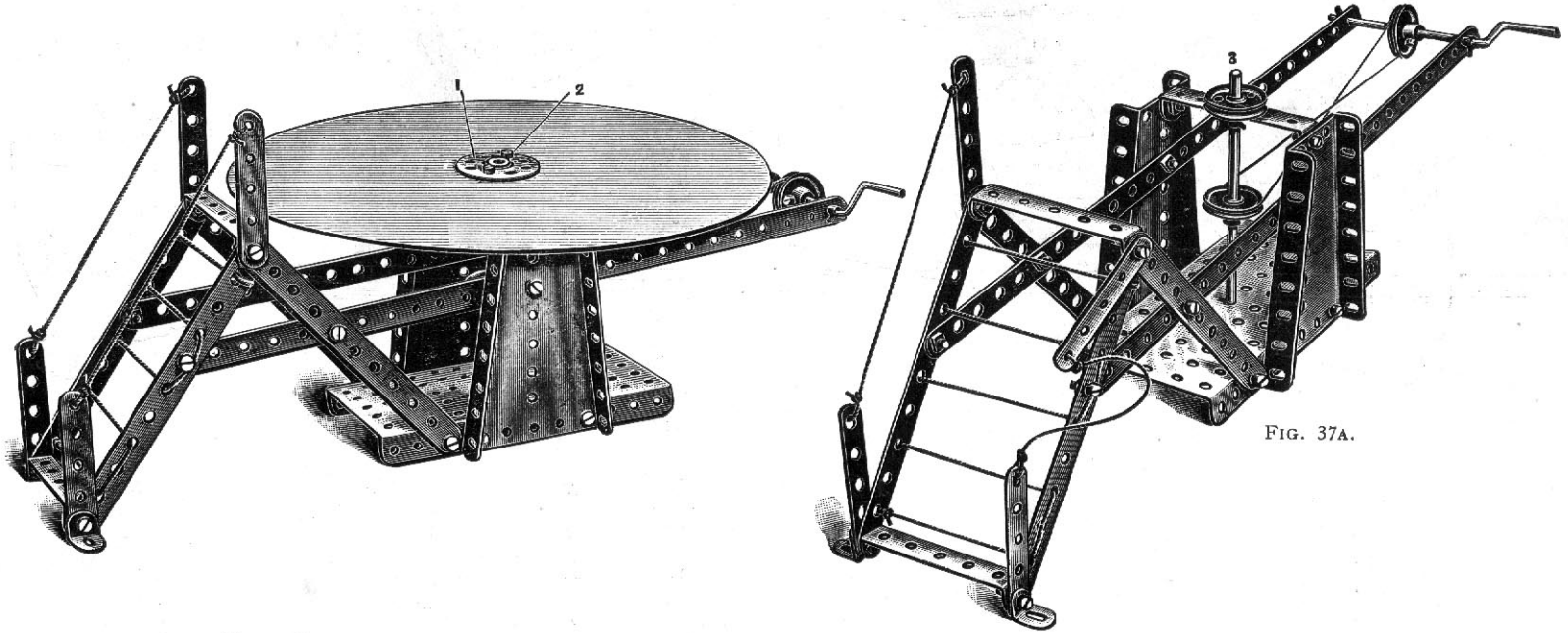

FIG. 37A.

PARTS REQUIRED.

2 of No. 1	3 of No. 22
4 " " 2	1 " " 24
4 " " 5	3 " " 35
3 " " 60	20 " " 37
2 " " 12	1 " " 52
1 " " 15	2 " " 54
1 " " 19	

The driving mechanism and construction of the framework of this model are clearly brought out in Fig. 37A. Cut out a circular piece of cardboard, 8" in diameter, and in the centre of the disc fix a bush wheel 1 by nuts and bolts 2. The eye of the bush wheel is then threaded over the top of the vertical spindle 3, and secured by its set screw.

Round-about

(MADE WITH MECCANO OUTFIT NO. 1.)

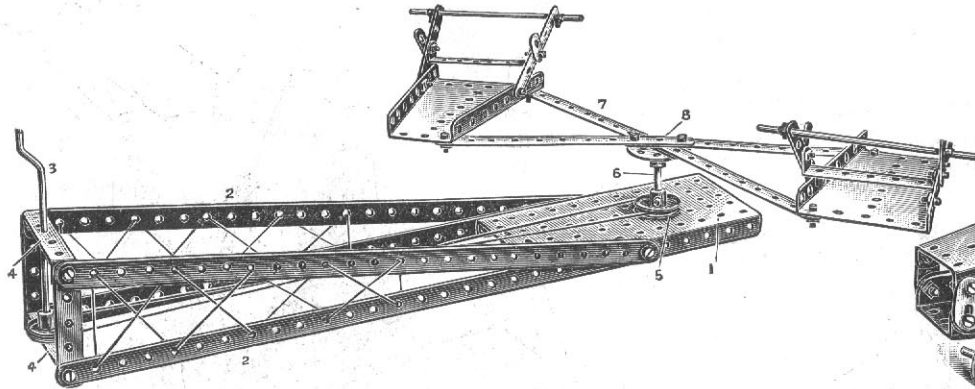

PARTS REQUIRED.

4 of No. 1
4 " " 2
6 " " 5
4 " " 10
2 " " 15
1 " " 17
1 " " 19
3 " " 22
1 " " 24
5 " " 35
20 " " 37
1 " " 52
2 " " 54
4 " " 60

In this model, begin by making the platform from the flanged plate 1 and 12½" strips 2. The bearings of the crank handle 3 are formed in 2½" bent strips 4. The drive from the pulley on the crank is taken to a 1" pulley 5, fast on the spindle 6, another similar pulley being secured to the spindle beneath the flanged plate. The arms 7, formed of four 5½" strips, are bolted to a bush wheel 8 fast on the spindle 6

Motor Cart

(MADE WITH MECCANO OUTFIT NO. 1.)

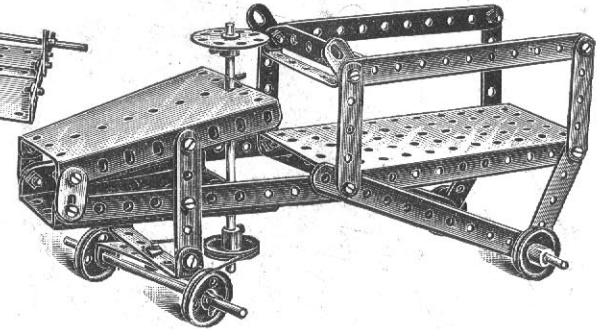

PARTS REQUIRED

6 of No. 2
8 " " 5
4 " " 10
3 " " 15
3 " " 22
2 " " 22A
1 " " 24
3 " " 35
20 " " 37
1 " " 52
2 " " 54
4 " " 60

Snow Plough

(MADE WITH MECCANO OUTFIT NO. 1.)

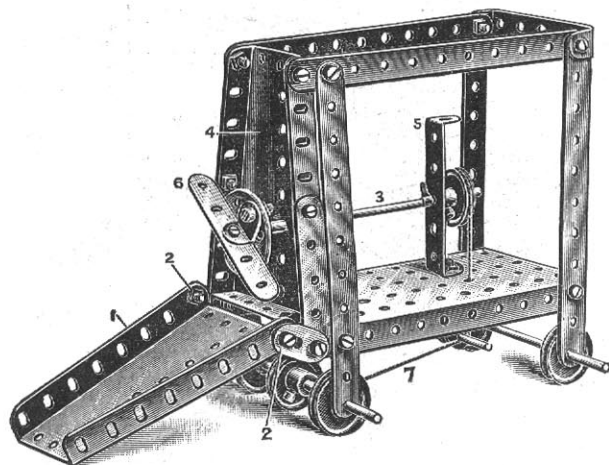

PARTS REQUIRED.

6 of	No.	2
3 "	"	5
2 "	"	60
2 "	"	10
1 "	"	12
3 "	"	15
1 "	"	17
4 "	"	22
2 "	"	22 ^Δ
1 "	"	24
4 "	"	35
19 "	"	37
1 "	"	44
1 "	"	52
2 "	"	54

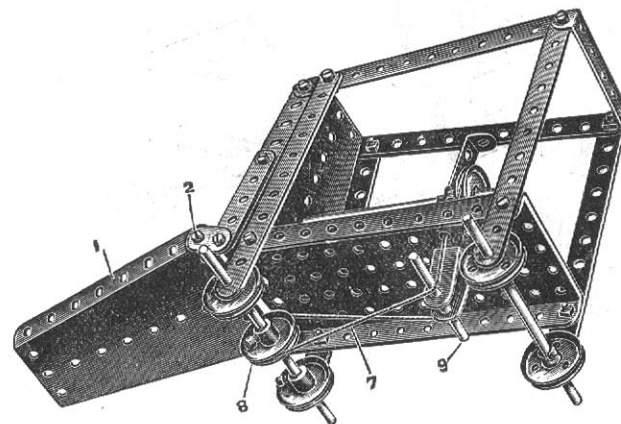

FIG. 40A.

The construction of the framework of this Model presents no difficulty. The sector plate 1 forming the plough is loosely pivoted on the bolts 2. The axle 3 is mounted in the front sector plate 4 and the $2\frac{1}{2}$ " bent strip 5. A $2\frac{1}{2}$ " strip 6 is bolted by angle brackets to a bush wheel on the front of the axle and forms a dispersing propeller for the snow after it rises up the inclined sector plate 1. A continuous cord 7 is passed round a 1" pulley wheel 8 and round a short axle 9 and a 1" pulley wheel on the propeller axle. In this way, as the plough is moved along the track, the propeller is revolved.

Potter's Wheel

(MADE WITH MECCANO OUTFIT NO. 1.)

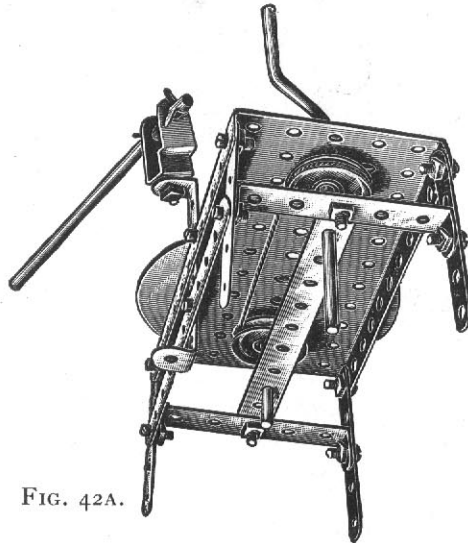
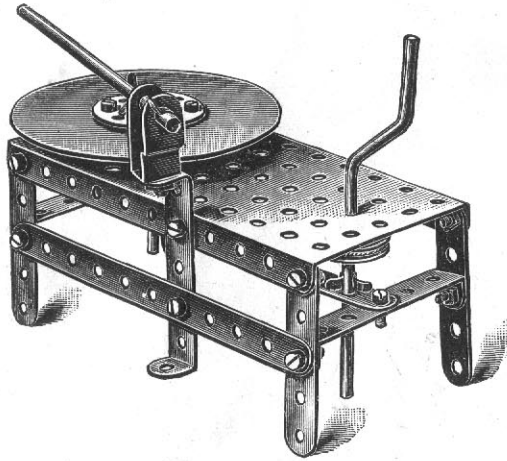

FIG. 42A.

PARTS REQUIRED.

2 of No.	2
4 "	5
3 "	60
1 "	15
1 "	17
1 "	19
2 "	22
1 "	24
3 "	35
16 "	37
1 "	44
1 "	52

Drilling Machine

(MADE WITH MECCANO OUTFIT NO. 1.)

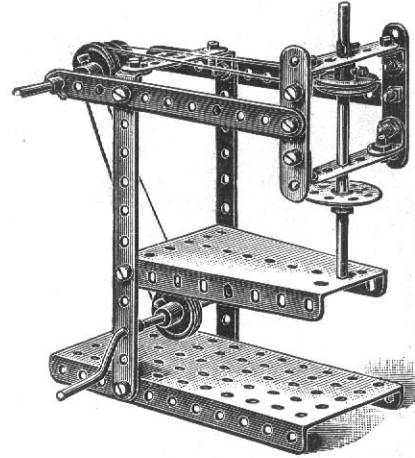

PARTS REQUIRED.

4 of No.	2
5 "	5
6 "	12
2 "	15
1 "	19
4 "	22
1 "	24
4 "	35
18 "	37
1 "	52
1 "	54

Churn

(MADE WITH MECCANO OUTFIT NO. 1.)

PARTS REQUIRED.

6 of No.	2
4 "	5
2 "	12
2 "	15
1 "	19
2 "	22
2 "	22A
1 "	24
5 "	35
19 "	37
1 "	52
2 "	54
3 "	60

Hoisting Block

(MADE WITH MECCANO OUTFIT NO. I.)

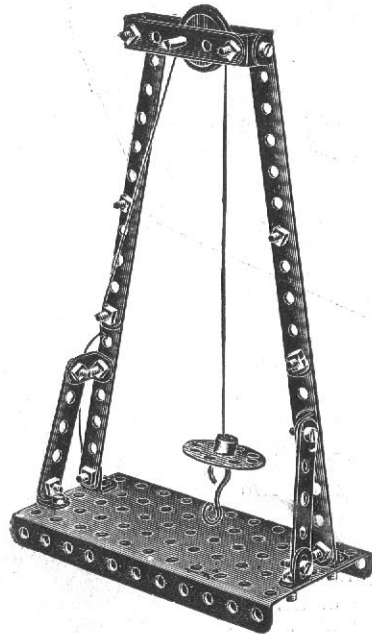

PARTS REQUIRED.

4 of No.	2
3 " "	5
8 " "	12
1 " "	17
1 " "	22
1 " "	24
22 " "	37
1 " "	52
1 " "	57
1 " "	60

Pit Headgear

(MADE WITH MECCANO OUTFIT NO. I.)

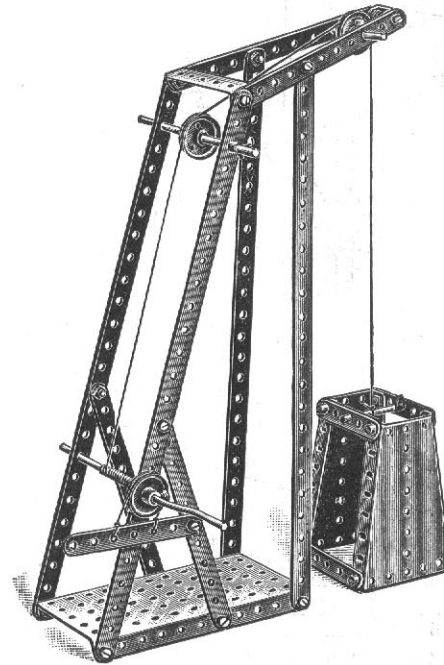

PARTS REQUIRED.

4 of No.	1
4 " "	2
1 " "	3
4 " "	5
1 " "	11
1 " "	15
1 " "	17
1 " "	19
3 " "	22
2 " "	35
24 " "	37
1 " "	52
2 " "	54

Tower Wagon

(MADE WITH MECCANO OUTFIT NO. 1.)

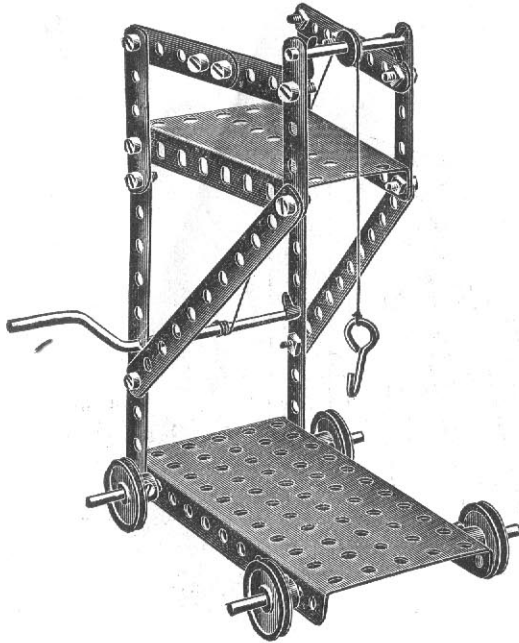

PARTS REQUIRED.

4 of No. 2	1 of No. 23
8 " " 5	4 " " 35
2 " " 15	18 " " 37
1 " " 17	1 " " 52
1 " " 19	1 " " 54
4 " " 22	1 " " 57

Ship

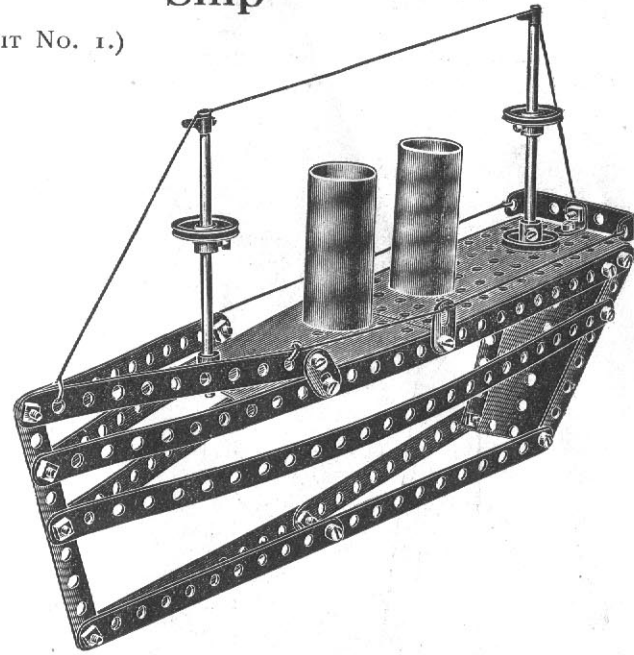

The bow of this ship is formed by two $2\frac{1}{2}$ " strips overlapped one hole, and the funnels rest on two 1" pulley wheels bolted to the plates.

PARTS REQUIRED.

4 of No. 1	4 of No. 22
6 " " 2	2 " " 22A
2 " " 5	2 " " 35
1 " " 60	22 " " 37
4 " " 10	1 " " 52
1 " " 12	2 " " 54
2 " " 15	

Drop Stamp

(MADE WITH MECCANO OUTFIT NO. 1.)

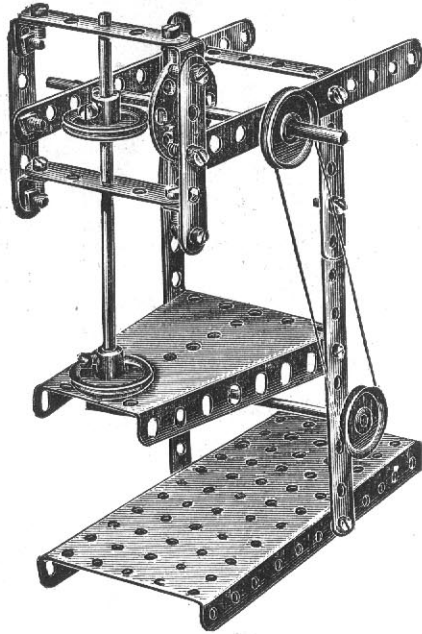

The stamp of this model is raised and dropped by a $2\frac{1}{2}$ " strip attached to a bush wheel.

PARTS REQUIRED.

4 of No. 2	4 of No. 22
7 " " 5	1 " " 24
1 " " 60	2 " " 35
4 " " 12	20 " " 37
2 " " 15	1 " " 52
1 " " 19	

Automatic Dial Press

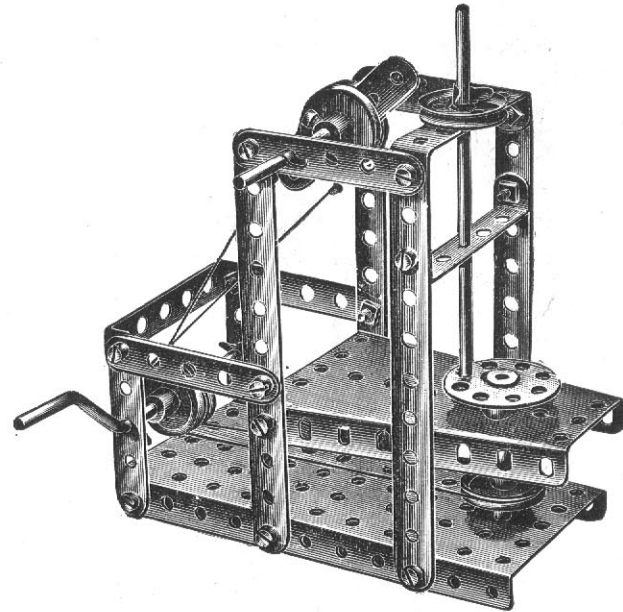

PARTS REQUIRED.

4 of No. 2	2 of No. 22A
7 " " 5	1 " " 24
3 " " 60	6 " " 35
2 " " 15	18 " " 37
1 " " 17	1 " " 52
1 " " 19	1 " " 54
4 " " 22	

Level Crossing Barrier

(MADE WITH MECCANO OUTFIT NO. 1.)

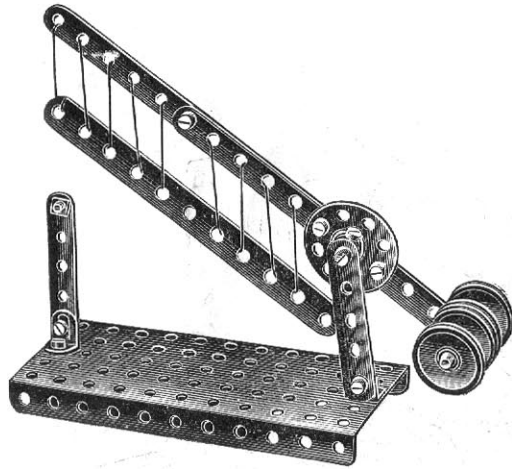

PARTS REQUIRED.

3 of No.	2
2 " "	5
2 " "	12
1 " "	17
4 " "	22
1 " "	24
9 " "	37
1 " "	52

Polishing Spindle

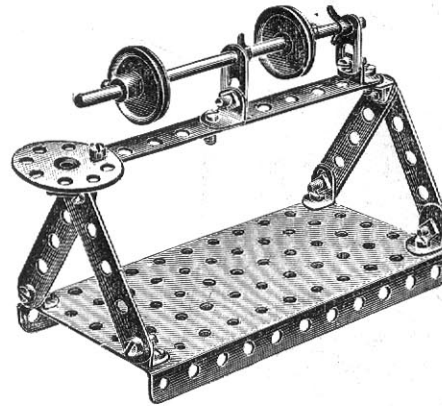

PARTS REQUIRED.

1 of No.	2
4 " "	5
2 " "	10
8 " "	12
1 " "	15
2 " "	22
1 " "	24
2 " "	35
15 " "	37
1 " "	52

Ore Crusher

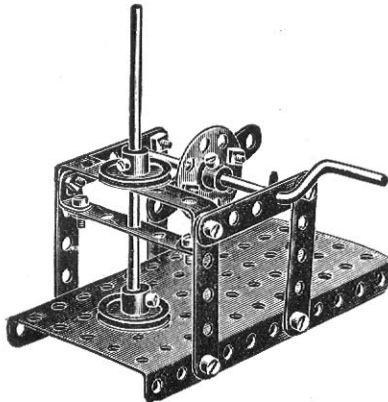

PARTS REQUIRED.

8 of No.	5
2 " "	12
1 " "	15
1 " "	19
2 " "	22
1 " "	24
2 " "	35
12 " "	37
1 " "	52
1 " "	60

Buffing Spindle

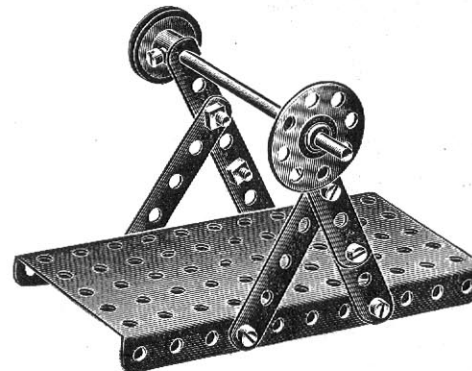

PARTS REQUIRED.

6 of No.	5
1 " "	15
1 " "	22
1 " "	24
8 " "	37
1 " "	52

Types of Lathes

(MADE WITH MECCANO OUTFIT NO. 1.)

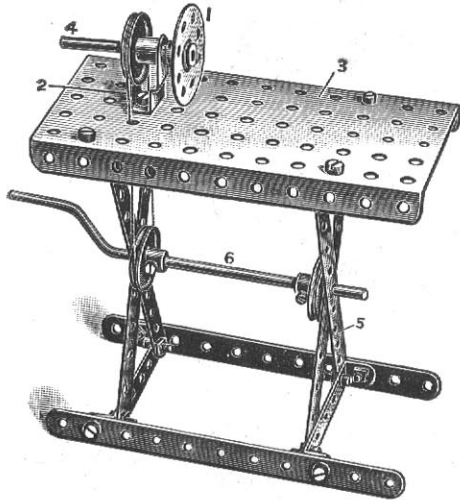

PARTS REQUIRED.

6 of No.	2
2 "	60
4 "	12
1 "	17
1 "	19
3 "	22
1 "	24
17 "	37
1 "	44
1 "	52

This is a very interesting little model, and much amusement can be derived by fixing a piece of modelling clay on the face of the bush wheel 1 and turning various shapes. A single bent strip 2 bolted to the flanged plate 3 carries the spindle 4 of the head-stock. The diagonal legs 5 carrying the driving spindle 6 are bolted by angle brackets to the under side of the plate 3.

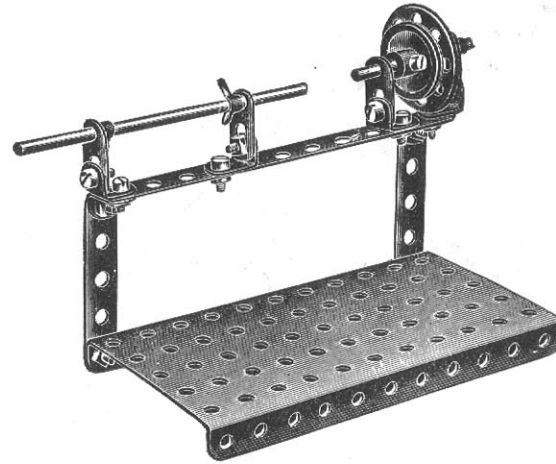

PARTS REQUIRED.

1 of No.	2
2 "	5
4 "	10
6 "	12
1 "	15
1 "	17
1 "	22
1 "	24
3 "	35
12 "	37
1 "	52

Swivelling Crane

(MADE WITH MECCANO OUTFIT NO. 1.)

PARTS REQUIRED.

4 of No. 2
4 " " 5
4 " " 12
2 " " 17
1 " " 19
3 " " 22
1 " " 22A
2 " " 35
16 " " 37
1 " " 44
1 " " 52
1 " " 54
1 " " 57
1 " " 60

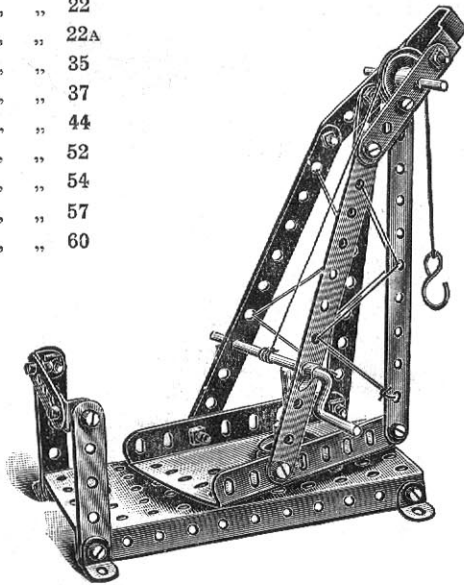

Racing Motor

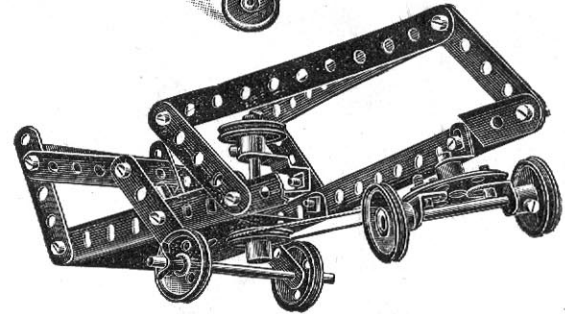
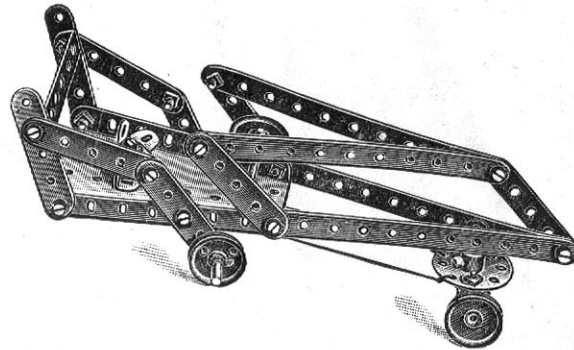

PARTS REQUIRED.

4 of No. 2	2 of No. 22A
9 " " 5	1 " " 24
2 " " 10	2 " " 35
1 " " 11	21 " " 37
4 " " 12	1 " " 44
1 " " 15	1 " " 54
2 " " 17	1 " " 60
4 " " 22	

The sector plate of the Crane in this model is pivoted to the base.

Gangway

(MADE WITH MECCANO OUTFIT NO. 1.)

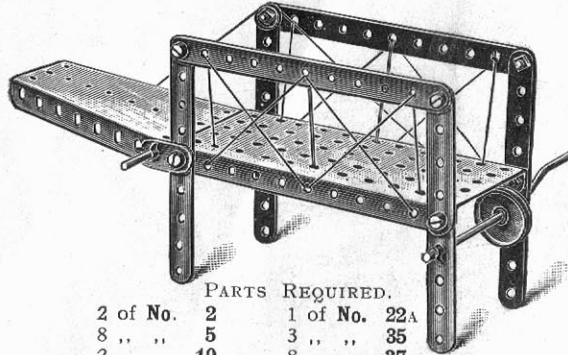

PARTS REQUIRED.

2 of No.	2	1 of No.	22A
8 " "	5	3 " "	35
2 " "	10	8 " "	37
1 " "	15	1 " "	52
1 " "	19	1 " "	54
1 " "	22		

Stamping Mill

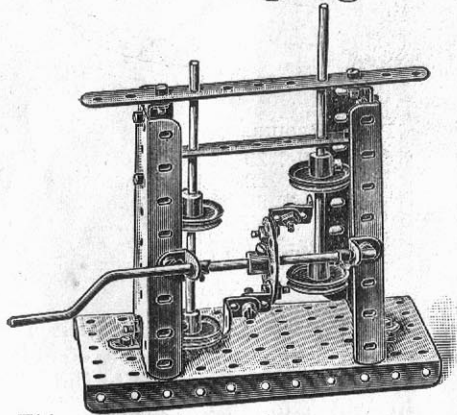

PARTS REQUIRED.

1 of No.	2
1 " "	3
12 " "	12
2 " "	15
1 " "	19
4 " "	22
1 " "	24
2 " "	35
18 " "	37
1 " "	52
2 " "	54

This model shows the usual type of Stamp for crushing ore. The stamps are lifted by means of angle brackets bolted to a bush wheel on the cranked handle, engaging the upper 1" pulley wheels on the Stamp spindles.

Carrier Tricycle

(MADE WITH MECCANO OUTFIT NO. 2 OR NO. 1 AND NO. 1A.)

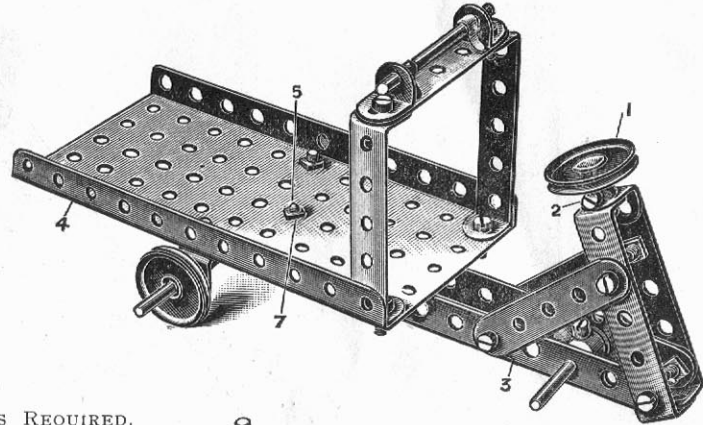

PARTS REQUIRED.

2 of No.	2
3 " "	5
1 " "	11
2 " "	12
1 " "	15
2 " "	17
3 " "	22
1 " "	24
2 " "	35
16 " "	37
1 " "	52
5 " "	60

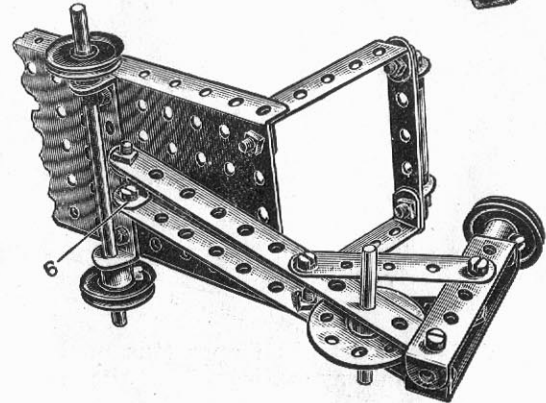

The general construction of this model is shown clearly in the illustrations. The seat 1 is a 1" pulley which is secured by its set screw 2 to a bolt passed from beneath into the bush of the wheel. The rear frame 3 is pivoted to the rectangular plate 4 about a bolt 5, passed through a double bracket 6, between which and the plate 5 a lock-nut (see standard detail D at the end of the manual) is inserted, the upper nut 7 securing the frame 3 in place.

Mechanical Navyy

(MADE WITH MECCANO OUTFIT NO. 2 OR NO. 1 AND NO. 1A.)

Motor Van

PARTS REQUIRED.

6 of No.	1
5 " "	2
2 " "	3
5 " "	5
4 " "	8
1 " "	10
1 " "	17
3 " "	15
1 " "	19
4 " "	20
1 " "	22
2 " "	22A
6 " "	35
43 " "	37
1 " "	52
2 " "	54
2 " "	60

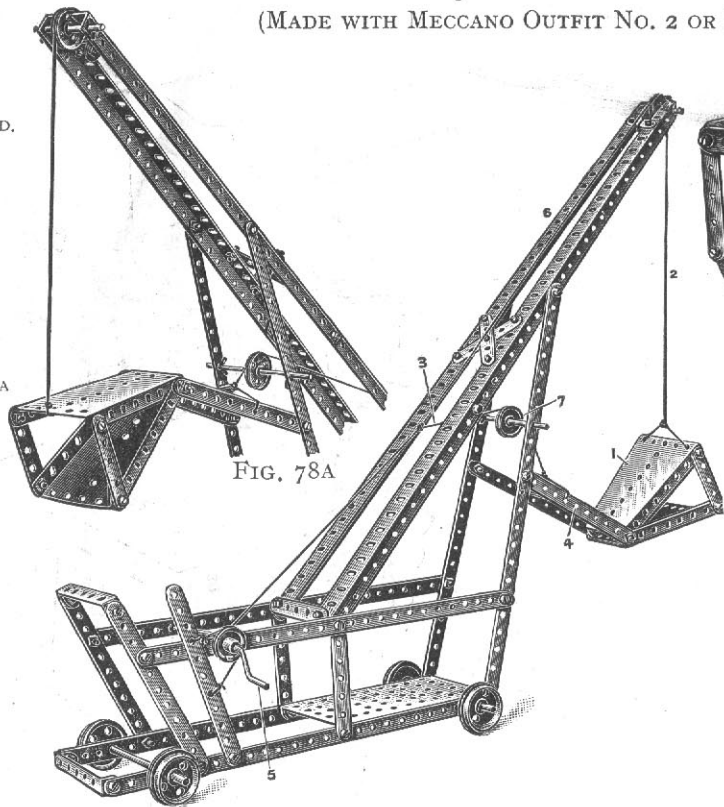
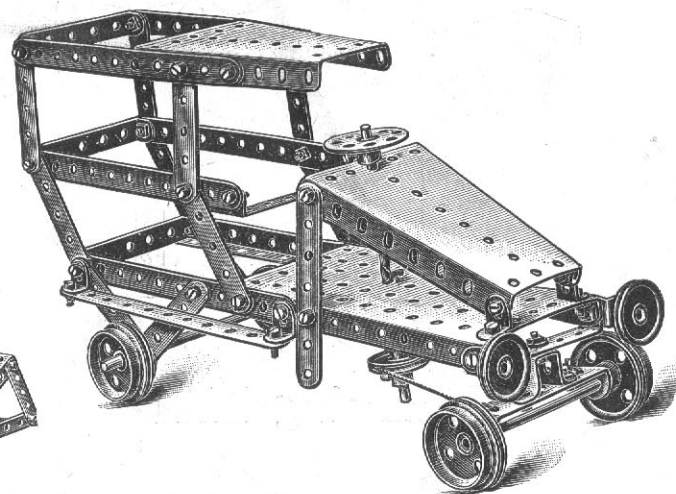

FIG. 78A



PARTS REQUIRED.

3 of No.	2	4 of No.	20	1 of No.	45
2 " "	3	3 " "	22	1 " "	52
12 " "	5	1 " "	24	2 " "	54
8 " "	12	1 " "	35	6 " "	60
3 " "	15	40 " "	37		

This is a model of an apparatus used for excavating canals, docks, railway cuttings, &c. The jib 6 is fixed, and the grab bucket 1 is pivoted at the ends of the 5½" strips 4 which are in turn pivoted to the jib. The operating cord 2 passing round the cranked handle and connected to the bucket 1 is coupled to another cord 3, which passes over a pulley 7 and is connected to the 5½" strips 4. This arrangement gives the scooping position shown and an emptying position illustrated in the detail Fig. 78A.

The steering wheel rod 4½" is fitted below with a 1" pulley, round which the steering cord is given a complete turn to ensure a good grip and is then connected to the outer holes of a 2½" bent strip, which forms the bearing for the front wheel axle, and which is pivoted to another 2½" bent strip reversed, bolted to the flanges of a flanged plate beneath the sector plate. The double bent strip is lock-nutted as in standard detail D.

Merry-go-round

(MADE WITH MECCANO OUTFIT No. 2, OR No. 1 AND No. 1A.)

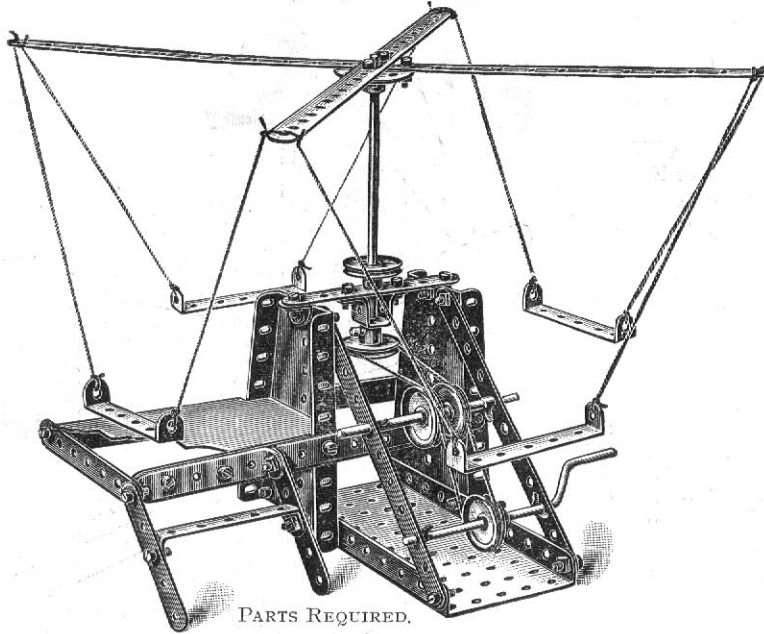

PARTS REQUIRED.

2 of No. 1	1 of No. 16	33 of No. 37
4 " " 2	1 " " 19	1 " " 45
2 " " 3	3 " " 22	1 " " 52
4 " " 5	2 " " 22A	2 " " 54
3 " " 12	1 " " 24	6 " " 60
1 " " 15	4 " " 35	

The side frames of this model are sector plates bolted to a flanged plate for the base, and connected across at the top by a $2\frac{1}{2}$ " strip beneath which is bolted a double bent strip forming the bearing for the spindle of the Merry-go-round arms. The driving cord passes from a 1" pulley on the cranked handle over two loose pulleys and round a pulley fixed on the spindle. The platform for mounting the suspended boats is carried from the main structure by overlapped $5\frac{1}{2}$ " and $2\frac{1}{2}$ " strips.

Ferry Gangways

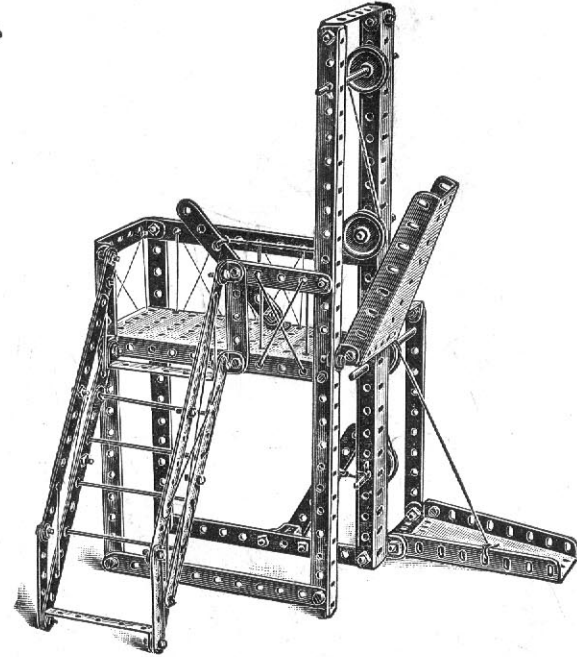

The vertical standard 1 is built up from two angle girders, the slotted holes overlapped to form a channel section girder.

PARTS REQUIRED.

14 of No. 2	2 of No. 22
2 " " 3	2 " " 22A
6 " " 5	6 " " 35
3 " " 8	50 " " 37
2 " " 10	1 " " 45
7 " " 12	1 " " 52
2 " " 15	2 " " 54
2 " " 17	6 " " 60

Steamship

(MADE WITH MECCANO OUTFIT NO. 2 OR NO. 1 AND NO. 1A.)

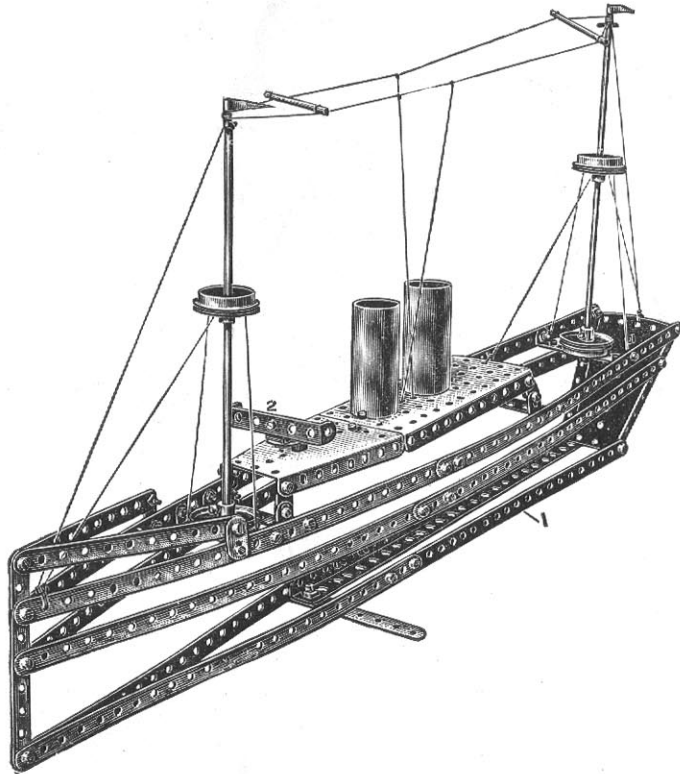

PARTS REQUIRED.

10 of No.	1
3 " "	2
2 " "	3
4 " "	5
2 " "	8
6 " "	10
12 " "	12
4 " "	15
2 " "	17
4 " "	20
2 " "	22
1 " "	24
2 " "	35
59 " "	37
1 " "	52
2 " "	54
2 " "	60

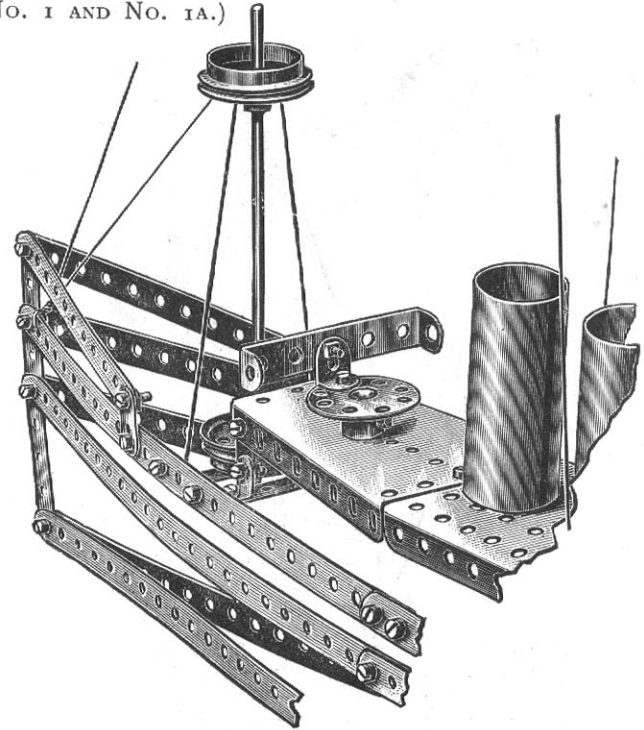

This is a model the construction of which will interest all boys. The rear keel plates 1 are of angle girders to give rigidity. A $2\frac{1}{2}$ " bent strip 2 is bolted by an angle bracket to a bush wheel to form the bridge, the upper deck being made from a large flanged plate and a sector plate, connected together by a $2\frac{1}{2}$ " strip beneath. The funnels rest over fast pulley wheels connected to the plates by bolts passed through the plates and nipped in the bushes of the pulley wheels.

Embossing Machine

(MADE WITH MECCANO OUTFIT NO. 2 OR NO. 1 AND NO. 1A.)

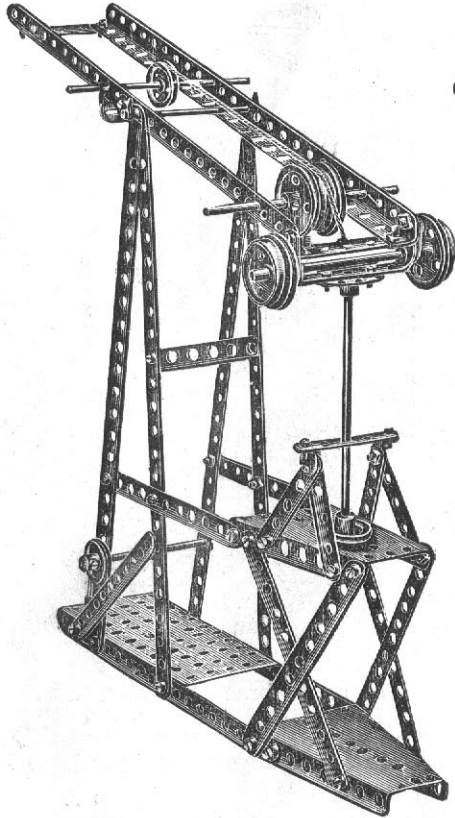

PARTS REQUIRED.

4 of No.	1	4 of No.	20
9	2	2	22
7	5	1	22A
2	8	1	24
2	10	5	35
3	12	43	37
4	15	1	12
1	16	2	54
1	19	2	60

Cake Walk

(MADE WITH MECCANO OUTFIT NO. 3 OR NO. 2 AND NO. 2A.)

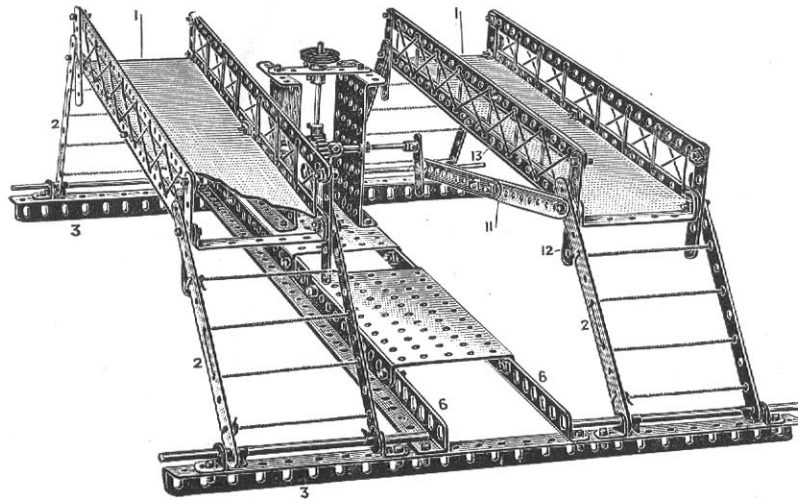

PARTS REQUIRED.

8	of	No.	1
12	"	"	2
9	"	"	5
6	"	"	8
8	"	"	12
6	"	"	15
1	"	"	22
1	"	"	26
1	"	"	32
8	"	"	35
62	"	"	37
2	"	"	52
2	"	"	53
3	"	"	59
6	"	"	60
2	"	"	62

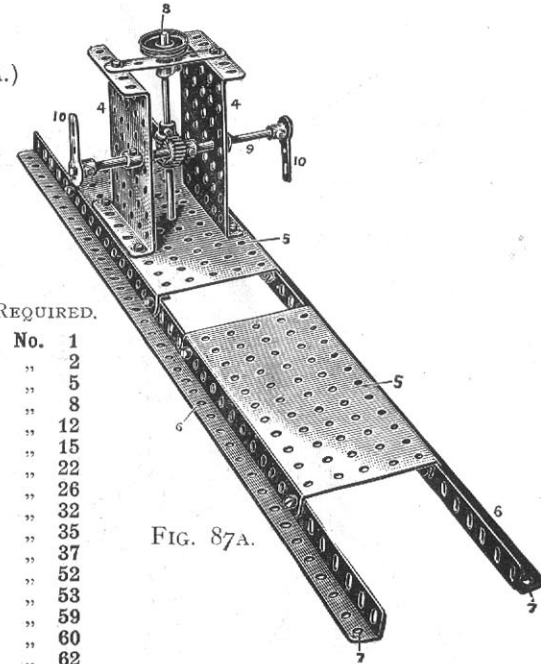
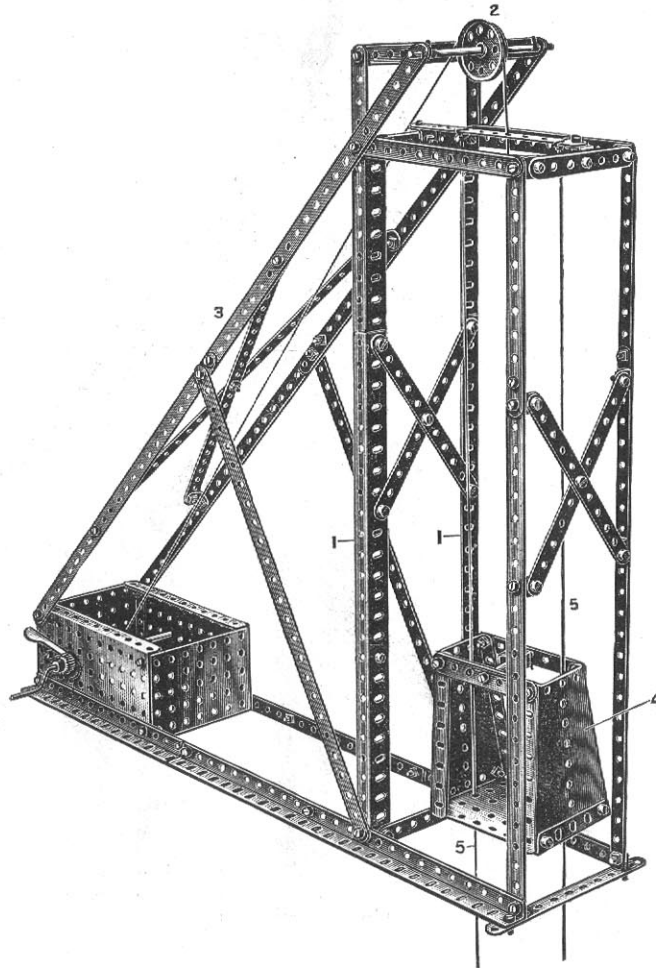

FIG. 87A.

This model comprises two side platforms 1 carried upon $5\frac{1}{2}$ " strips 2 pivoted to angle brackets bolted to angle girders 3. The gear box, Fig. 87A, consists of small flanged plates 4 bolted to a large flanged plate 5, which in turn is bolted to angle girders 6 overlapped fourteen holes. It is necessary to bolt the flanges to the flanged plate 5 outside the vertical parts of the angle girders 6 so that the end holes 7 shall register with the holes in the angle girders 3. The platforms 1 are rocked from a vertical shaft 8 gearing with a shaft 9 by a worm and pinion, the ends of the shaft 9 being fitted with cranks 10 pivotally bolted to connecting rods 11 formed of two $5\frac{1}{2}$ " strips overlapped two holes. The strips 11 are also pivotally bolted to the end strips 2, a vertical $2\frac{1}{2}$ " strip 12, and the lower end hole of the lower strip 13 of each side platform, so as to give free rocking movement.

Pit Headgear

(MADE WITH MECCANO OUTFIT NO. 3 OR NO. 2 AND NO. 2A.)



PARTS REQUIRED.

10 of No.	1	1 of No.	21
10 "	2	1 "	26
6 "	3	1 "	33
4 "	5	76 "	37
8 "	8	6 "	35
1 "	11	2 "	52
14 "	12	3 "	53
1 "	15	2 "	54
1 "	17	1 "	59
1 "	19		

This model shows the principle upon which minerals are raised from below the ground. The main uprights 1 are formed of angle girders overlapped, and the pulley 2, over which passes the winding rope 2, is carried on an axle rod passed through 2½" strips and the end hole of the diagonal bracing strips 3 made from 12½" strips overlapped three holes. The cage is made from sector plates 4 connected by 3½" strips at the top and a small flanged plate at bottom through the side holes in which the guide ropes 5 pass. The gear box is made from large flanged plates at the side and small flanged plates at the end.

Travelling Swivel Crane

(MADE WITH MECCANO OUTFIT NO. 3 OR NO. 2 AND NO. 2A.)

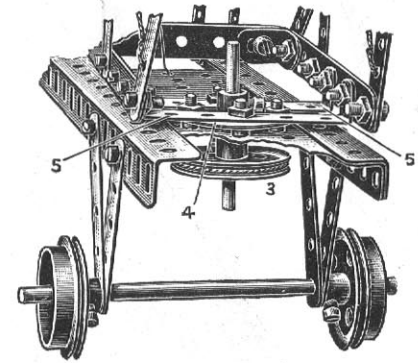
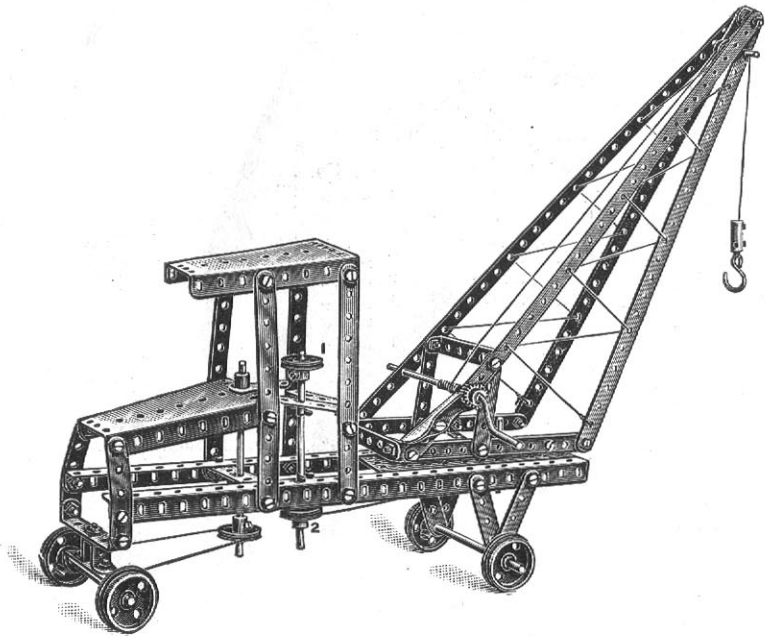

FIG. 93A.

The steering mechanism of this model is the same as in the Motor Van. The swivelling action of the jib is controlled by a handwheel 1 on an axle rod, at the foot of which is another 1" pulley 2, round which passes the operating cord to a 1½" pulley 3 on a 2" rod, to which is secured a bush wheel 4 bolted to 2½" bent strips 5, Fig. 93A. Bolts are inserted in four holes of the bush wheel, the heads of which keep the crane from tilting sideways as it swivels.

PARTS REQUIRED.

4 of	No. 1	1 of	No. 22A
6	2	1	24
2	3	1	26
11	5	1	33
2	8	6	35
1	11	51	37
2	12	1	45
3	15	1	52
1	16	2	54
2	17	1	57
1	19	6	60
4	20	1	62
1	21	1	63
3	22		

Railway Wagon Swivel Crane

(MADE WITH MECCANO OUTFIT NO. 3 OR NO. 2 AND NO. 2A.)

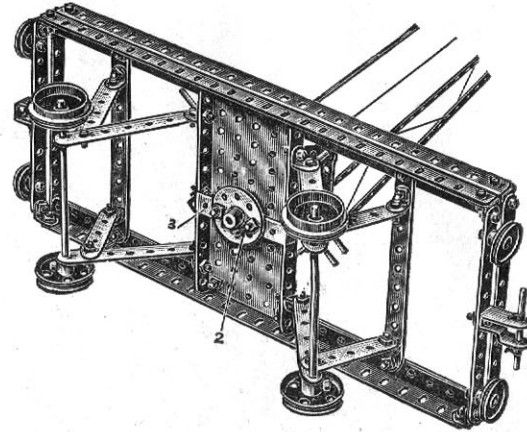
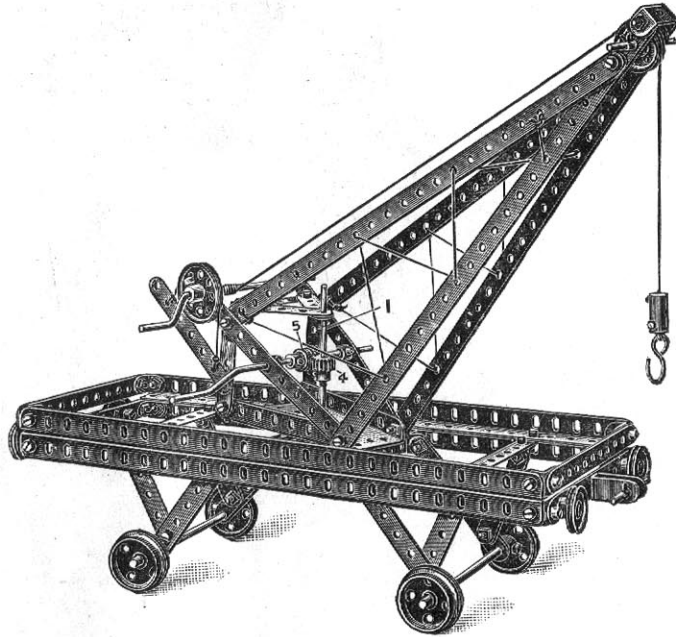

PARTS REQUIRED.

4	of	No.	1	1	of	No.	22A
8	"	"	2	1	"	"	24
5	"	"	3	1	"	"	26
9	"	"	5	1	"	"	32
4	"	"	8	5	"	"	35
1	"	"	11	69	"	"	37
16	"	"	12	1	"	"	44
3	"	"	15	1	"	"	45
2	"	"	17	1	"	"	52
2	"	"	19	1	"	"	54
4	"	"	20	1	"	"	57
1	"	"	21	2	"	"	59
4	"	"	22	2	"	"	60

The swivelling action of this model is obtained as follows: The spindle 1 is fixed against rotation in a bush wheel 2 bolted to a cross $2\frac{1}{2}$ " bent strip 3 beneath the wagon. The pinion 4 on the spindle 1 is therefore fixed, and when the worm 5 is rotated by the cranked handle the whole crane rotates about the pinion.

Lever Balanced Luffing Jib Crane

(MADE WITH MECCANO OUTFIT NO. 3 OR NO. 2 AND NO. 2A.)

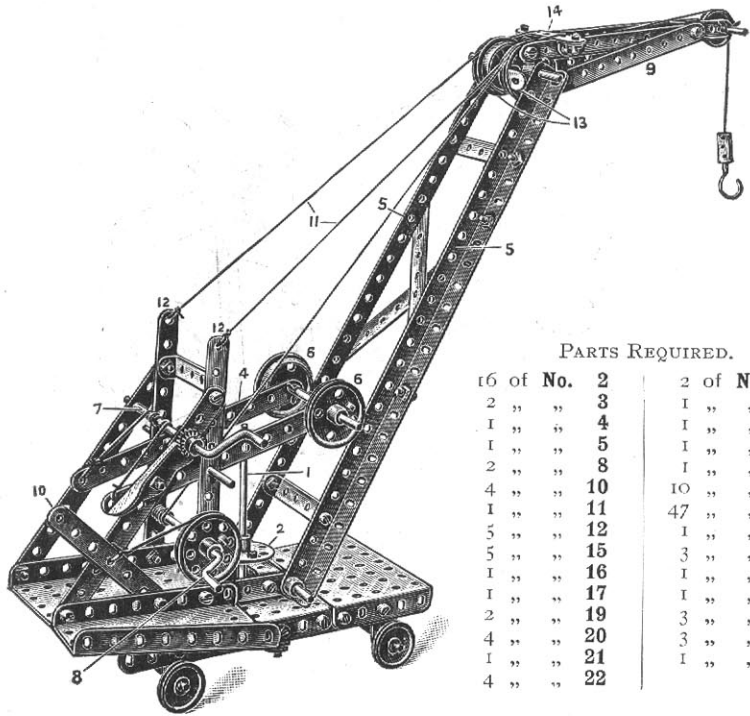

PARTS REQUIRED.

16 of No. 3	2 of No. 22A
2 " " 4	1 " " 23
1 " " 5	1 " " 24
1 " " 8	1 " " 26
2 " " 10	1 " " 33
4 " " 11	10 " " 35
1 " " 12	47 " " 37
5 " " 15	1 " " 52
5 " " 16	3 " " 53
1 " " 17	1 " " 54
1 " " 19	1 " " 57
2 " " 20	3 " " 59
4 " " 21	3 " " 60
4 " " 22	1 " " 63

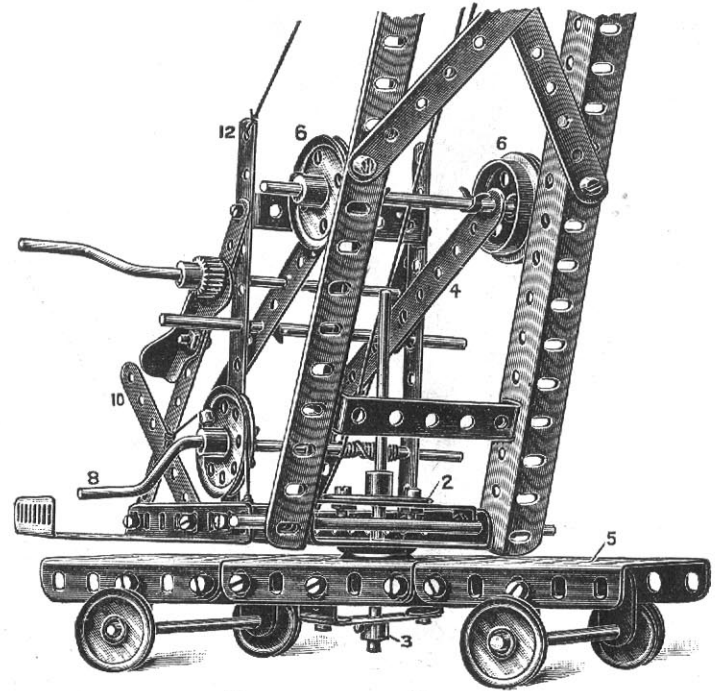
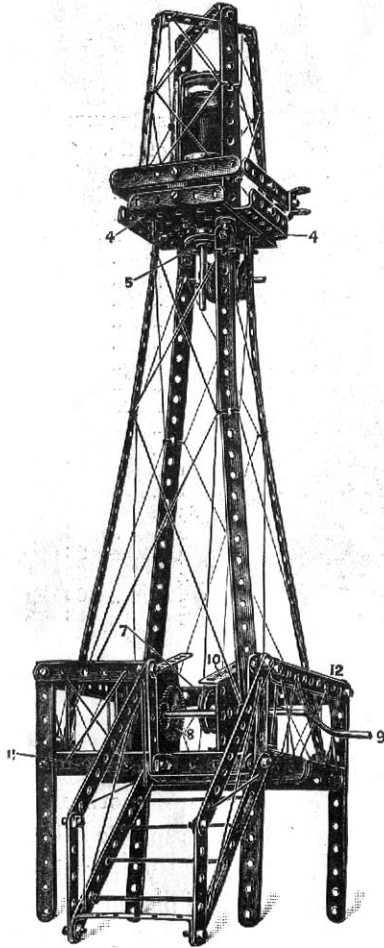

FIG. 95A.

The trolley platform is made up of three small flanged plates fastened together by $5\frac{1}{2}$ " strips on the inside of their flanges. The crane pivots about a rod 1 fixed in a bush wheel 2, and provided at its foot with a collar 3, as shown in detail, Fig. 95A. The luffing of the jib is effected by the pivoted strips 4 engaging the angle girders 5 of the jib by means of the flanged wheels 6, the strips 4 being connected to a double winding cord on the cranked handle axle 7. The load is raised by the cranked handle 8 and is swung out by the balanced lever 9 as the jib is luffed. A brake handle 10 is fitted (see standard detail A). The cords 11 are fixed at 12, carried over the flanged wheels 13, and fixed to the $2\frac{1}{2}$ " strip 14. The base 15 is made from three small flanged plates fastened together by a $5\frac{1}{2}$ " strip bolted to the inside of the flanges.

Revolving Lighthouse

(MADE WITH MECCANO OUTFIT NO. 3 OR NO. 2 AND NO. 2A.)



PARTS REQUIRED.

4 of No. 1	2 of No. 22A
12 " " 2	1 " " 25
4 " " 3	1 " " 27
1 " " 4	4 " " 35
6 " " 5	73 " " 37
4 " " 10	1 " " 44
1 " " 11	1 " " 45
20 " " 12	2 " " 52
2 " " 16	2 " " 53
1 " " 17	2 " " 54
1 " " 19	1 " " 59
2 " " 20	6 " " 60
2 " " 22	

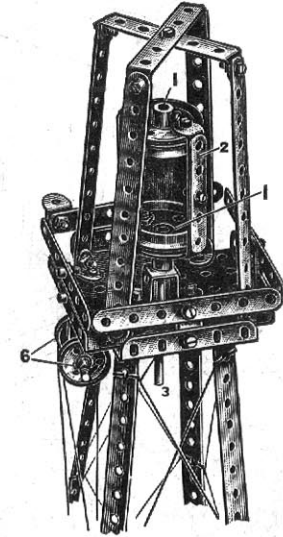

The revolving lantern is made from two flanged wheels 1 distanced by $2\frac{1}{2}$ " bent strips 2, the lower wheel is fixed to a rod 3 and is passed through two crossed flanged plates 4, and has a 1" pulley 5 fixed beneath, round which the operating cord passes and is led over two 1" pulley wheels 6 to a lower pulley wheel 7 on an axle rod driven by gear wheels 8 from the cranked handle 9. The cranked handle and the gear wheels are journalled in sector plates 10 forming the side frames, which are bolted to two flanged plates 11 separated to fit within the $5\frac{1}{2}$ " strips 12 of the railing framework of the platform.

Swing Bridge

(MADE WITH MECCANO OUTFIT NO. 4 OR NO. 3 AND NO. 3A.)

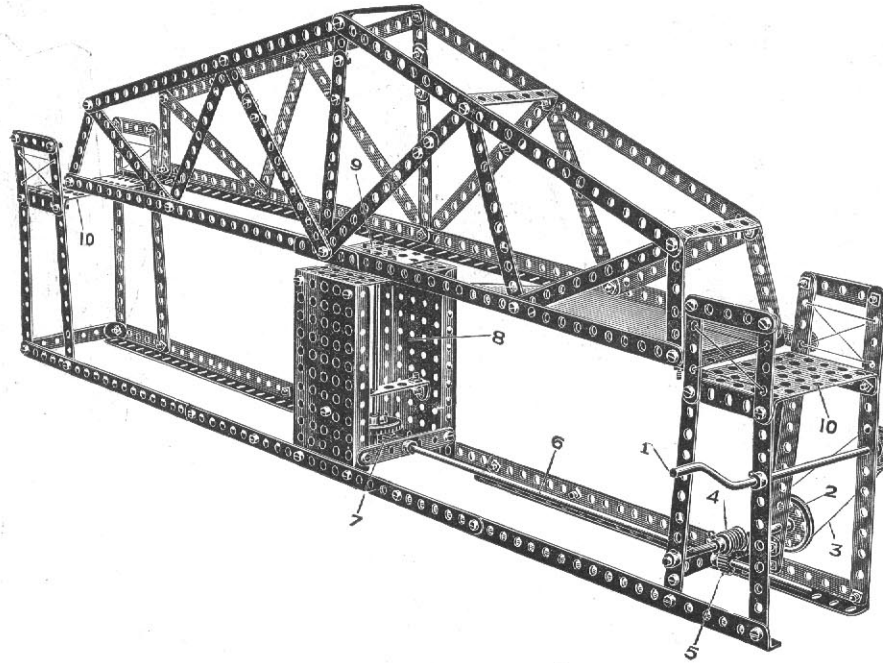

PARTS REQUIRED.

6	of	No.	1
22	"	"	2
6	"	"	3
4	"	"	4
19	"	"	5
8	"	"	8
6	"	"	12
1	"	"	13
2	"	"	15
1	"	"	16
1	"	"	19
1	"	"	21
1	"	"	22
1	"	"	24
2	"	"	26
1	"	"	28
1	"	"	32
85	"	"	37
2	"	"	52
4	"	"	53
4	"	"	59
5	"	"	60
1	"	"	63

The construction of this model will be quite apparent from the illustration. The crank handle 1 drives a pulley 2 by means of the cord 3. On the pulley spindle 2 is fixed a worm 4 geared with a $\frac{1}{2}$ " pinion 5 on the axle 6, another $\frac{1}{2}$ " pinion on the end of which drives a contrate wheel 7 on the vertical spindle 8 which carries the bridge, this spindle being secured to a bush wheel fastened to the under side of the small flanged plate 9 in the centre of the bridge. By operating the handle 1 the bridge may be swung round to the open position, or its ends brought opposite to the landing platforms 10.

Battleship

(MADE WITH MECCANO OUTFIT NO. 4 OR NO. 3 AND NO. 3A.)

The main lines of the model can be easily followed from the illustration, the upper structure and bridge being built up separately as shown in Fig. IIIA. The base of the upper structure is made from two large flanged plates 1, to the ends of which are bolted two sector plates 2 carrying the fore and aft guns. These are made from flanged pulley wheels 3 on vertical spindles 4 forming the pivot of the gun, the gun itself being formed from pieces of axle rod 5, to the ends of which are gripped two couplings 6 threaded on the vertical rod 4 and held in place by collars 7. Above the large flanged plates 1 two smaller flanged plates 8 are bolted, which carry the masts 9 stepped into 1" pulley wheels 10 and secured beneath by collars. The outer flanges of the plates 1 are bolted to the gunwale strips 11. The funnels 12 are made from the metal cylinders supplied, which are sprung over the 1" pulley wheels 13 and closed at the top by other pulley wheels.

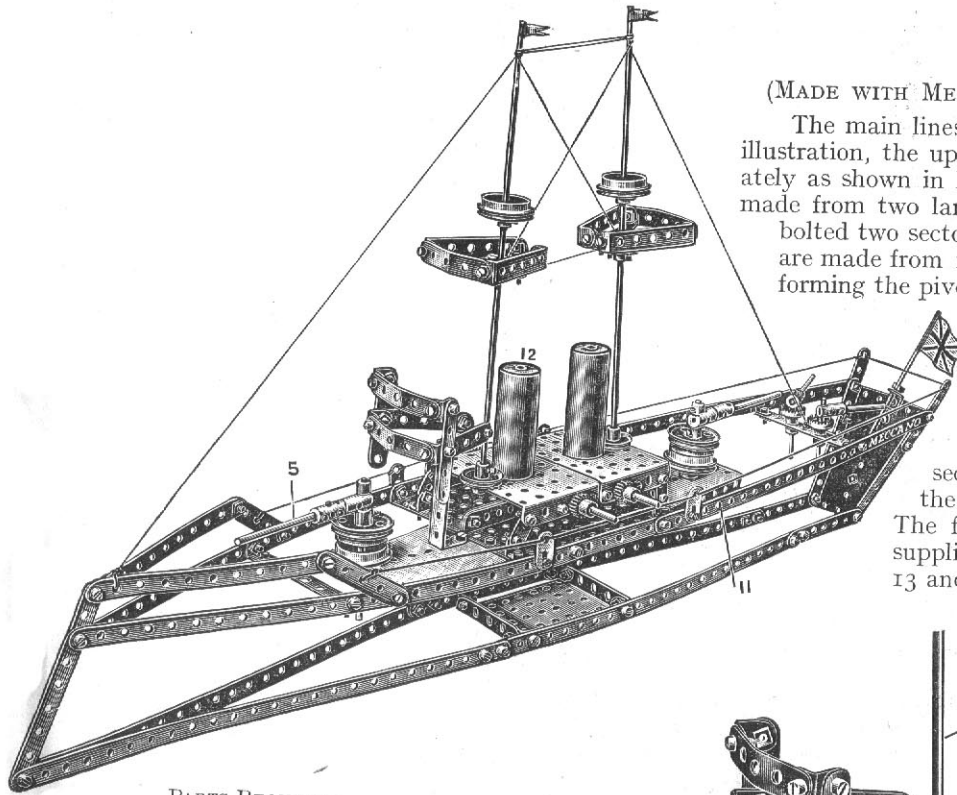

PARTS REQUIRED.

8 of No. 1	1 of No. 23
2 " " 2	2 " " 24
5 " " 3	2 " " 25
14 " " 5	2 " " 26
8 " " 10	2 " " 29
1 " " 11	1 " " 35
19 " " 12	101 " " 37
2 " " 13	1 " " 46
2 " " 14	2 " " 52
1 " " 15	3 " " 53
4 " " 16	3 " " 54
4 " " 17	8 " " 59
6 " " 20	8 " " 60
4 " " 22	6 " " 63
2 " " 22A	

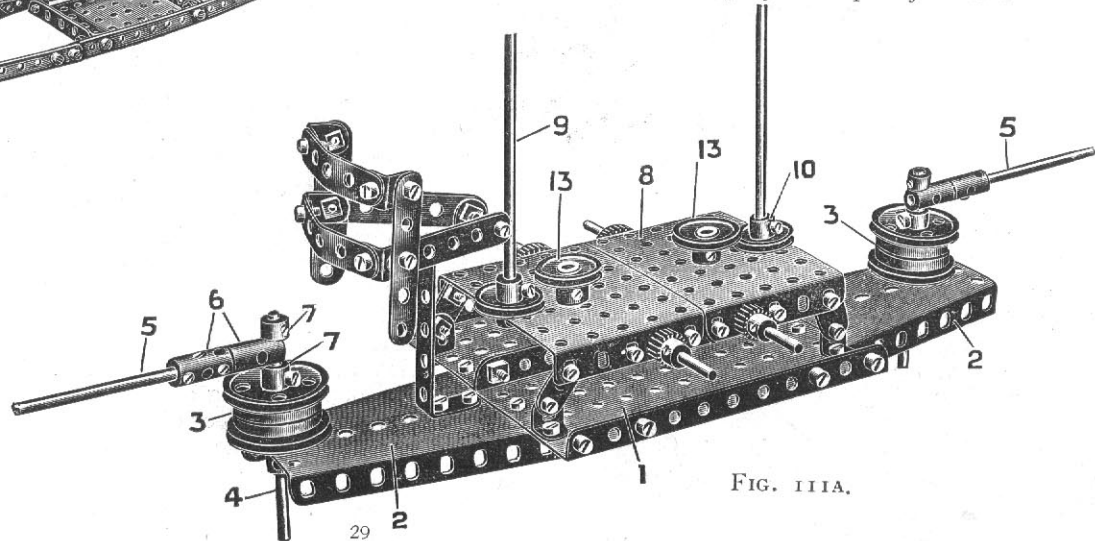
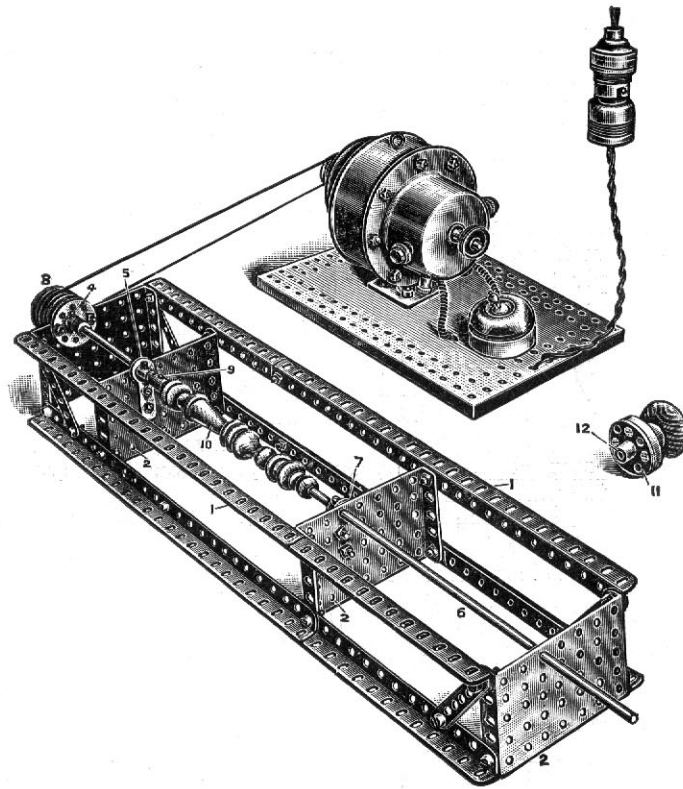

FIG. IIIA.

Turning Lathe

(MADE WITH MECCANO OUTFIT NO. 4 OR NO. 3 AND NO. 3A.)



PARTS REQUIRED.

4 of	No. 4	4
8 "	" "	8
1 "	" "	13
1 "	" "	14
2 "	" "	20
1 "	" "	24
30 "	" "	37
4 "	" "	53
1 "	" "	59
2 "	" "	62

This model is but one example of the great practical possibilities to which the Meccano system of construction may be applied. The illustration shows a model lathe, the framework of which is built very rigidly of overlapped angle girders 1, to which are bolted by their flanges four small flanged plates 2, the fast headstock of the lathe being provided by a 5" rod, one end journalled in a bush wheel 4 bolted to the end plate, and the other journalled in the boss of a crank 5. The loose headstock is formed by an axle 6 journalled in the end plate 2, and a crank 7 bolted to the inner plate. The drive from the motor is carried round two flanged wheels 8 butted together on the headstock spindle, on the other end of which is gripped a coupling 9 by one of its screws, this coupling being also secured to a centre fork driven into the article 10 to be turned. The detail view to the right shows how a knob or other article may be screwed to a bush wheel 11, the base 12 of which is gripped by its screw to the headstock spindle to form a chuck or face plate. The electric motor shown in the illustration is one-thirtieth horse-power, the price of which will be found at the end of the manual.

Dutch Windmill

(MADE WITH MECCANO OUTFIT NO. 4 OR NO. 3 AND NO. 3A.)

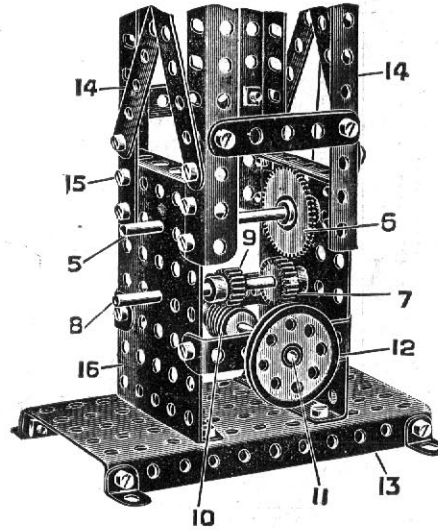
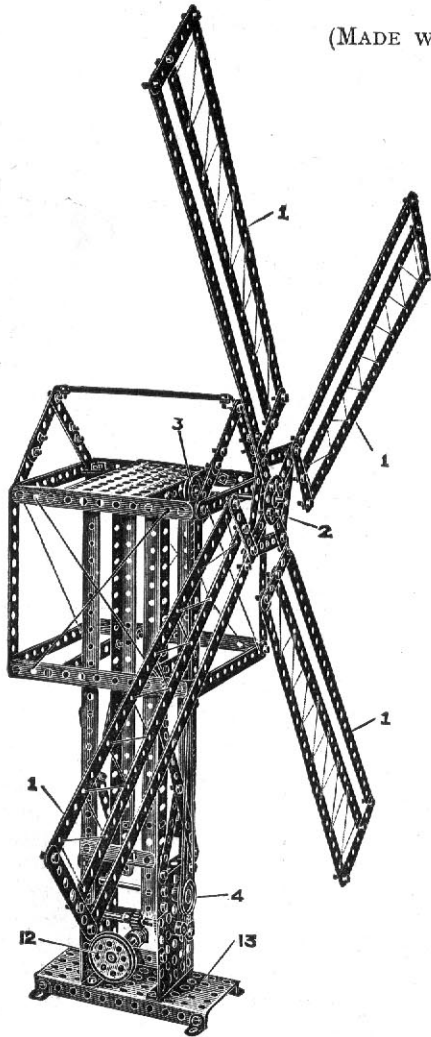

PARTS REQUIRED.

	12 of	No.	1
	19	" "	2
	4	" "	3
	4	" "	4
	14	" "	5
	4	" "	8
	22	" "	12
	1	" "	14
	3	" "	16
	1	" "	21
	2	" "	22
	1	" "	24
	1	" "	25
	1	" "	26
	1	" "	27
	1	" "	32
	120	" "	37
	2	" "	52
	2	" "	53
	3	" "	59
	2	" "	60

FIG. 113A.

The construction of the sails 1 of the mill will be readily followed from the illustration. They are bolted to an inner strip frame 2 and to a bush wheel fixed on a spindle, on which is also mounted a pulley wheel 3, the driving cord passing round this pulley wheel to a lower pulley wheel 4, the driving of which will be followed from the detail. The pulley wheel 4 is on the outer end of the shaft 5, on which is fitted a gear wheel 6 driven by a $\frac{3}{4}$ " pinion 7 on the axle 8, this axle also carrying a $\frac{1}{2}$ " pinion 9 engaged by a worm 10 on the driving shaft 11, which carries the driving pulley 12. This driving gear is enclosed in two small side flanged plates 16 bolted to a base plate 13, the vertical stroke of the mill being made from corner angle girders 14 bolted at 15 to the side plates 16.

Vertical Saw

(MADE WITH MECCANO OUTFIT NO. 4 OR NO. 3 AND NO. 3A.)

PARTS REQUIRED.

12 of	No. 1	2 of	No. 25
12 "	" 2	2 "	" 26
4 "	" 3	1 "	" 27
2 "	" 4	1 "	" 28
5 "	" 5	1 "	" 32
8 "	" 8	2 "	" 35
20 "	" 12	99 "	" 37
1 "	" 14	1 "	" 45
5 "	" 15	2 "	" 52
1 "	" 16	3 "	" 53
3 "	" 17	1 "	" 54
8 "	" 20	6 "	" 59
1 "	" 21	2 "	" 62
3 "	" 22	1 "	" 63

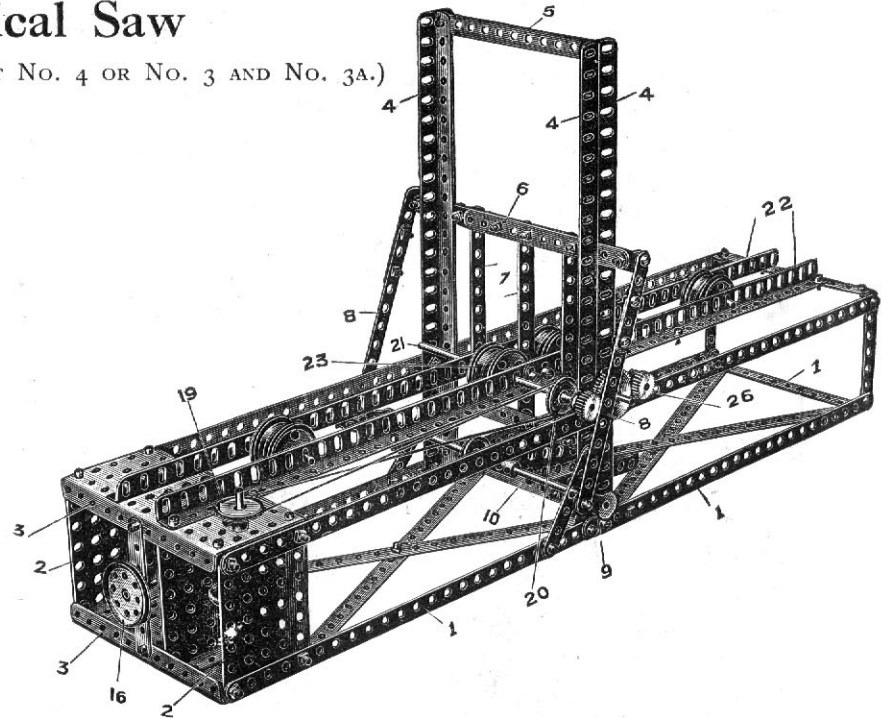

This model represents a log-sawing machine in which a number of saws are moved vertically up and down while the log is fed forward to the saws and cut into planks. The base framework of the model is formed of strips 1 connected to small flanged plates 2, forming the sides, and large flanged plates 3, forming the top and bottom of the gear box. Angle girders 4 are bolted to the strips 1 to form vertical guides for the saw frame, a strip 5 being bolted between the flanges and the angle girders to give clearance for the frame strips 6 carrying saws 7 which slide between the angle girders 4. The frame 6 is moved vertically up and down by the connecting rods 8 lock-nutted to the ends of the upper strips 6, and cranks 9 secured on the end of an axle rod 10. This rod 10 is driven by a cord 11 passing over a pulley wheel 12 on a rod 13, which is driven by a pinion 14 engaging with a worm on the driving shaft 15, this driving shaft being fitted with a driving pulley 16. To provide for the travel of the logs, the other end of the rod 13 is fitted with a pinion 17 engaging a contrate wheel 18 on a vertical spindle, the upper end of which is fitted with a pulley wheel 19, the driving cord passing round this pulley 19 to a similar pulley 20 on an axle 21 journalled in the vertical webs of the angle girder rails 22. This rod 21 carries the flanged wheels 23, and is geared by a pinion 24 engaging a gear wheel 25 to another pinion 26 carrying another pair of flanged wheels. The log is carried along on these flanged wheels through the saws 7.

Vertical Saw (continued)

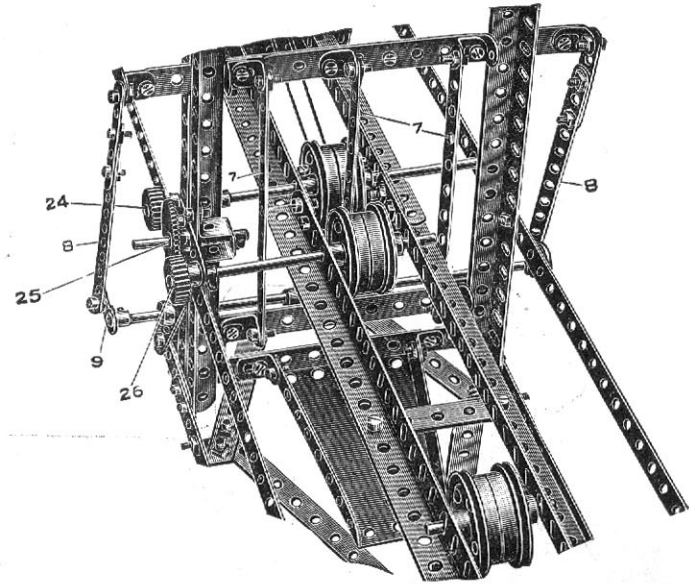
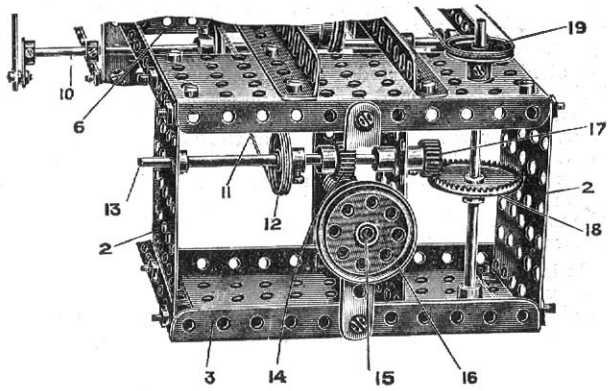
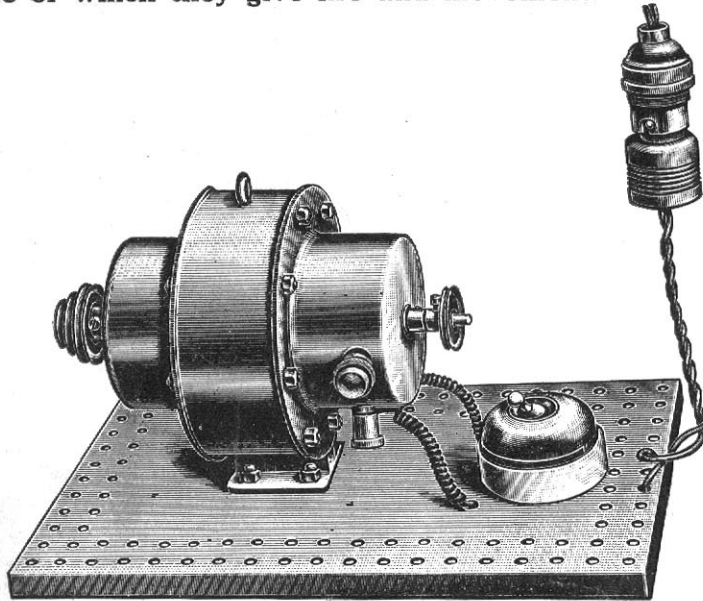

FIG. 114A.

MECCANO MOTORS

ONE of the principal merits of Meccano is that all the models which it makes are *working models*. No greater pleasure for any boy can be imagined, than for him to take a number of elementary parts, piece them together with his own hands and in his own way, and then to see the results of his efforts and skill move and work in a precise and scientific way. The Meccano Motors will encourage this very natural pleasure. They have been designed on Meccano lines, and are specially suited to work Meccano models, to each one of which they give life and movement.



The field coils are former wound, and are protected with best quality Empire cloth and good tapes, and when completed are thoroughly insulated by dipping in good-quality shellac varnish. They are then stoved and baked previous to placing in the magnet frame. All standard machines are of the series-wound type. The advantage of this is that they can be started on full load without damage to the motor. No bad effects will result from the sudden stoppage or jamming of the motor. This is a very important feature.

Meccano Electric Motor

The Meccano Electric Motor differs from all previous types of electric motors, being totally enclosed, thus eliminating all fear of shock. This is absolutely essential where the motor is to be run by inexperienced users in the home. It has a very high finish of nickel-plating, and it is designed on sound mechanical principles. It is intended to be used in connection with models where a greater power is required than is provided by the spring motors, e.g. for working such models as the lathe shown on page 30, or a number of models at one time. It provides for continuous running, and the motion is started and stopped by the simple movement of a switch. This switch is fitted to the base of the motor, and is connected with a flexible wire attached to an adaptor to enable it to be readily connected to any lampholder.

It is necessary to see that the motor purchased corresponds to the voltage of the current with which it is to be connected. Care should be taken not to use a 110-volt motor on a current of 230 volts, as the effect would be to damage it.

Specification

The machines are of the self-contained type, and are so arranged that they can be turned through angles of 90° or 180° , thus allowing the motor to be bolted to either the wall or ceiling, or in fact used in any convenient position.

The field frame consists of substantial cast-iron casing of good permeability, cast in one piece including the pole-pieces, and is of the Bi-polar type.

Meccano Motors *(continued)*

The **armature shaft** is of special mild steel designed to operate safely under the most severe working conditions. The armature core is built up of good-quality iron of the highest permeability, and each disc is carefully insulated and assembled directly on to the shaft between strong end-plates. The armature is of the slotted-drum type.

The **winding** is of the symmetrical drum type, each coil being carefully wound by experienced armature winders, and the coils are carefully insulated, varnished, and stoved. The coils when wound are held in position by fibre strips, which are placed in the mouth of the slots. The armature insulation has been given most careful attention, and is of fine-quality micanite. After the armature is completed, it is thoroughly dried at a temperature of about 200°.

The **commutator** consists of the requisite number of hard-drawn copper segments of high conductivity and ample depth, insulated with mica. After assembly the whole is subjected to heavy hydraulic pressure whilst at a high temperature, and when in such position the installing rings and sleeve are also under great pressure.

The **brush-holders** are of substantial design, and of the box type, the brush being kept on the commutator by direct pressure from springs fitted in the holders.

Each machine before despatching is subjected to a six-hours' test, run at full load, and its various parts are coupled up to run in a clockwise direction, when looked at from the commutator.

The motors are of one-thirtieth horse-power, and their speed is about 1,500 revolutions per minute, fully loaded.

Meccano electric motors are made either for 200 to 230 volts direct current, 100 to 120 volts direct current, or for 110 alternating current.

The essentials of an electric motor for running Meccano models are, that it shall be of the totally-enclosed and slow-speed type. The Meccano Electric Motor has been specially designed for the purpose, is practically "fool proof," and is finished, adjusted, and tested, regardless of cost. We recommend that no other type of motor be used for running Meccano Models. Our full guarantee is behind it. All the parts are interchangeable, and can be replaced at any time.

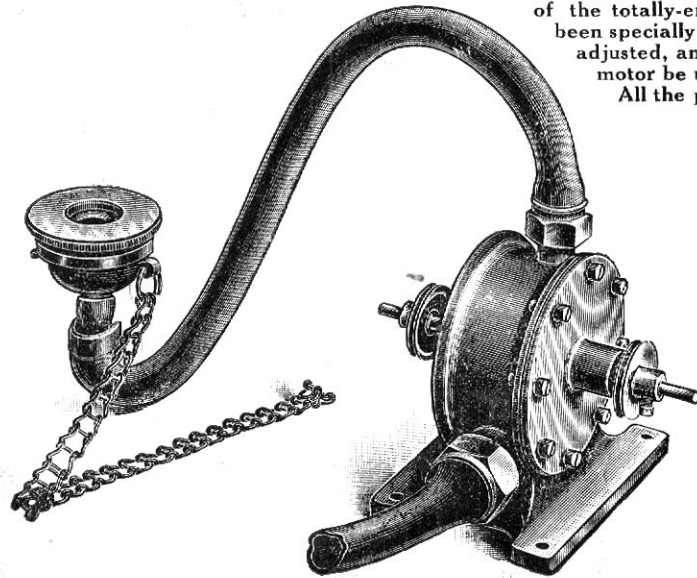

Price of either type .. 75/-

The **Meccano Water Motor** provides for the continuous working of models by the simple expedient of attaching it to any convenient water tap. It is an admirable substitute for the Meccano Electric Motor where electric current is not available. It is supplied with two tubes, one with an adaptor for attachment to the water tap, and the other to carry away the waste water. It is of one-sixtieth horse-power, at a pressure of 30lbs.

Meccano Water Motor, complete with tubes and fitting.

Price 16/6

